



A systematic review of hybrid quadrotor-track subsea robotic crawler for offshore mineral mining in the era of Industry 4.0

by M.O. Ojumu¹, A.K. Raji¹, E.F. Orumwense¹

Affiliation:

¹Department of Mechanical Engineering and Mechatronics Engineering, University of Technology, Bellville, South Africa

Correspondence to:

M.O. Ojumu

Email:

mikeoluwaseunojumu@gmail.com

Dates:

Received: 5 Jun. 2025

Revised: 29 Jan. 2025

Accepted: 29 Sept. 2025

Published: January 2026

How to cite:

Ojumu, M.O., Raji, A.K., Orumwense, E.F. 2026. A systematic review of hybrid quadrotor-track subsea robotic crawler for offshore mineral mining in the era of Industry 4.0. *Journal of the Southern African Institute of Mining and Metallurgy*, vol. 126, no. 1, pp. 35–62

DOI ID:

<https://doi.org/10.17159/2411-9717/3747/2026>

ORCID:

M.O. Ojumu

<http://orcid.org/0000-0003-4318-1115>

Abstract

The Fourth Industrial Revolution has driven significant advancements in autonomous robotic systems, particularly in subsea exploration and offshore mineral dredging. This review examines the latest developments in electrically powered quadrotor-track subsea robotic crawlers, highlighting their potential to enhance efficiency, mobility, and adaptability in challenging underwater environments. The integration of advanced automation, artificial intelligence, and real-time control systems has paved the way for more effective robotic solutions in offshore mining.

This study explores the dynamic performance of hydraulic crawlers to quadrotor-track robotic dredgers, focusing on their propulsion, navigation, and stability under high hydrodynamic conditions. By leveraging state-of-the-art technologies such as lithium-ion battery power systems, intelligent microprocessors, and sensor-based control mechanisms, these robotic crawlers offer a promising alternative to conventional subsea excavation methods. Furthermore, the review analyses recent experimental and simulation-based studies that assess the feasibility and performance of these systems in real-world applications.

The findings of this review provide valuable insights into the role of 4IR in transforming subsea robotics for offshore mineral dredging. By addressing existing limitations and identifying key technological advancements, this study contributes to the ongoing development of next-generation robotic systems capable of operating efficiently in extreme underwater conditions.

Keywords

Fourth Industrial Revolution (4IR), electrically powered robotics system, quadrotor-track subsea crawler, offshore mineral dredging, autonomous robotic systems, artificial intelligence in robotics, battery-powered underwater vehicles, sensor-based control mechanisms

Introduction

Seabed mining has evolved significantly with the advent of advanced technologies like the Underwater Remote Mining (URM) system, which utilises specialised crawlers for efficient and environmentally conscious extraction of submerged diamond deposits (President, Greve, 2022). In 2018, Arctic Canadian Diamond Company and IHC Mining collaborated with Burgundy Diamond Mines. They have been developing an innovative URM system designed to extract diamond-bearing kimberlite ore from deep open pits at the Ekati Diamond Mine in Canada's Northwest Territories. This system employs a remotely operated underwater mining crawler equipped with advanced control and positioning technology. The crawler excavates ore using a drum cutter, eliminating the need for blasting, and pumps the material to the surface through a vertical pipeline connected to a launch and recovery platform. This method is capable of operating at depths up to 400 metres and aims to reduce environmental impact by minimising waste extraction and the mine's overall footprint. The URM system is projected to extend the mine's operational life by at least a decade. Following this technology (track subsea robotic crawlers) Debmarine Namibia's offshore (2017) gave insights into their deployment of large, remotely operated crawlers that traverse the seabed at depths of around 150 metres to collect diamond-rich sediments, which are then processed onboard specialised vessels. The publication also highlights the effectiveness of this approach, noting that marine diamonds exhibit a higher percentage of gem-quality stones compared to land-based sources, which emphasised its significant contribution to advanced future crawler for ocean deep mining. Yeu et al. (2011) tested MineRo, a mining robot designed for shallow water mining with higher

A systematic review of hybrid quadrotor-track subsea robotic crawler for offshore mineral mining



Figure 1—Subsea dredging crawler (Yeu et al., 2011)

performance for dredging. In June 2009, it was tested at a 100 m depth with current sensor, 5 km off Hupo-port (Korean East Sea) to evaluate its ability to collect and lift manganese nodules. MineRo was tested at a depth of 120 metres in August 2012 to evaluate the integration of advanced technology, including automatic path-tracking control. A critical component of this control system was the implementation of a precise localisation algorithm. The researchers explored advancements in underwater navigation algorithms by estimating MineRo's kinematic parameters, including track slips and slip angles. These parameters were traditionally derived from Ultra-Short Baseline (USBL) position data and gyro sensor heading data, commonly integrated into state-of-the-art controllers, though its accuracy was affected by random noise. As of 2012, the study aimed to improve algorithm reliability by refining the measurement of these kinematic parameters.

The ocean floor is one of the most unexplored areas on Earth, and the increasing interest in underwater dredging has led to the development of various track robotic subsea exploration crawlers (TRSEC). Roland Holst (2024) investigated the ongoing debates surrounding seabed exploitation, highlighting the uncertainties regarding resource availability on land. This study critically examines the urgency and perceived inevitability of commercial deep-sea resource extraction, questioning whether it genuinely serves the common interest of humankind. Given that oceans cover 71% of the Earth's surface, they have been proposed as a significant source of essential minerals, bio-organisms, and energy. Authority (2006), provides an overview of polymetallic nodules, including their composition, formation, and potential for mineral extraction. The study examines the occurrence of these nodules in deep-sea environments and highlights the valuable metals they contain, such as manganese, nickel, copper, and cobalt. Additionally, it discusses deep-sea mining as an emerging method for mineral retrieval, conducted on the ocean floor in regions with extensive polymetallic nodule deposits or active and extinct hydrothermal vents located between 1,400 and 3,700 metres below the surface. These vents further established the importance of sulfide deposits that contain valuable metals, including diamond, gold, silver, copper, manganese, cobalt, and zinc.

Having established a standardised reference on Earth's subsea resources, the deep-sea mining process utilises electric pumps, hydraulic pumps, or bucket systems to transport minerals to the surface vessels or platforms for processing. However, like all mining operations, deep-sea mining presents significant challenges, including the impact of hydrodynamic forces on ocean-dredging machinery and potential environmental risks to surrounding

ecosystems as stated by Aung (2015). Zeng et al. (2022) presented the development of an advanced underwater robot that integrates quadrotor propulsion with bionic undulating fins to enhance manoeuvrability and operational efficiency in complex marine environments. It addresses the limitations of traditional subsea crawlers and introduces a hybrid propulsion system designed to improve mobility and adaptability.

As ocean mining continues to expand, subsea exploration crawlers play a crucial role in surveying and monitoring the ocean floor. These crawlers are typically equipped with sensors and cameras to collect environmental data and can be remotely operated or programmed for tasks such as crawling, sea dredging, and excavation. However, their movement is constrained due to direct contact with the seabed, limiting their manoeuvrability.

To mitigate this challenge, quadrotors can provide ocean robot support, complementing the capabilities of subsea crawlers. The MK3 ROST crawler used by the IMDH Group (2016), currently called Trans hex Group, while still effective in today's ocean mining market, has limited applications due to its size, track monitorabilities, and weight, and it requires significant energy to counteract the harsh hydrodynamic forces in underwater environments. In contrast, quadrotors offer a more efficient solution, leveraging their four-rotor configuration to achieve superior mobility and adaptability in challenging underwater conditions.

Configuring and designing a TRSEC with the best quad integration is a challenging task that requires careful mathematical modelling analysis with simulations using MATLAB. The principles of propulsion in a subsea environment deal with the forward power of the propeller, which is the same as the reverse power. The propeller system of the vehicle provides enough thrust to overcome the resistance of the surrounding water, which moves the vehicle through the underwater environment. This is affected by a number of factors, such as the rigid multibody configuration of the TRSEC, the size and shape of the propellers, the number and orientation of the blade configuration, and the power output of the electric motors that drive the propellers. Multibody system dynamics analysis is subsequently used to employ dynamic model interaction between the subsea crawler and quadrotors. The analysis provided insight into moving forces, moments, and torques acting on the system, as well as the trajectories of the quadrotors and the subsea crawler. Yum, et al. (2016 a; 2016b; 2016c), presented a mathematical model equation for a quad-x ocean crawler design using a multibody analysis. The objective of this investigation was to show the impact of drive configuration and design parameters on ocean vehicles. Speed, manoeuvrability, and stability were considered with a view to creating an industrial-based solution that minimises seabed crawler track slippages and improves the efficiency of underwater robots used for the purposes of extraction and surveillance. In areas of quadrotor dynamics, its focuses are on the thrust generation by propeller systems and their impact on vehicle motion due to hydrodynamics. It provides insights into the factors affecting thrust and the subsequent movement of the vehicle in an underwater environment as stated by Idrissi and Annaz (2020). In further discussion by Bian and Xiang (2018), they investigated theories on stability of multibody systems, particularly focusing on the interaction between vehicle dynamics and internal fluid sloshing. While it does not specifically address subsea crawlers with quadrotor, the methodologies discussed are applicable to analysing dynamic interactions in similar systems using track robots. Delving into the dynamics of flexible multibody systems using spatial

A systematic review of hybrid quadrotor-track subsea robotic crawler for offshore mineral mining

operators, offering a framework that could be applied to the analysis of subsea crawlers and their interaction with other dynamic systems like quadrotors, Jain and Rodriguez (1992) explored spatial operator methods to develop a novel dynamics formulation for flexible multibody systems. This formulation is designed to model the dynamics of flexible systems in a manner structurally identical to rigid multibody systems, facilitating the efficient manoeuvrability of ocean intervention rovers.

Xia et al. (2023) investigated the sinking and slippage of deep-sea mining vehicles (DSMV) while traveling on extremely soft sea floor sediments using a quadrotor arrangement. The study highlighted the vulnerability of DSMVs to dangerous situations such as overturning due to non-homogeneous sea floor sediments, heavy payload, and complex sea floor topography affected by high hydrodynamics in the ocean. The researchers focused on four-tracked DSMVs, which were found to have better traveling abilities and safety performances on uneven terrain compared to conventional dual-tracked vehicles. To enhance adaptability to uneven terrain, the tracks of the DSMVs were designed to be rotatable. To study the DSMV's traveling performance, a multi-body dynamics model of a specially designed four-tracked DSMV prototype was built using Recurdyn software. The model was modified to reflect the actual conditions of sea floor travel, including a more accurate shear model and adjustments for internal resistance, water resistance, and external loads. The track-soil force to the rear track was also modified based on the multi-pass effect, and a velocity coefficient was introduced to the resistance estimation equation. The study performed simulations of straight-line travel on soft ground with both fixed and rotatable tracks. By analysing the simulation results, the researchers studied the motion features and dynamic characteristics of the four-tracked DSMV with rotatable tracks when traveling on soft ground.

Hydraulic tractor ROST has been utilised successfully in dredging and mining operations for several years. It has several significant limitations, including low track driving abilities resulting from hydrodynamics, high hydraulic ocean pollution, and high energy consumption from the mechanical and electrical operating components. In a study to overcome these limitations, underwater crawlers powered by the most efficient thruster configuration method are being developed (Ojumu, 2022). These robotic crawlers are expected to provide better performance and improve subsea exploration. The outcomes of the study will serve as a basis for designing subsea exploration crawlers with quadrotors configuration, which can enhance the subsea environment dredging. Additionally, the findings will contribute to the advancement of robotics systems for subsea application. This proposal aims to investigate this approach in greater depth through a thorough literature review. Therefore, this research will suggest and recommend meaningful initiatives by government, policy makers, and researchers aimed at increasing the adoption of more ocean-friendly dredging robots for the extraction of the seabed floor resources.

Methodology

A systematic literature review (SLR) is commonly employed in

disciplines such as social sciences, education, global economics, retail business, and medicine. However, Moher et al. (2009 a) examined its application in the engineering field, demonstrating its effectiveness as an evidence-based research approach. The core principles of SLRs include being restrictive, duplicative, algorithmic, and collective.

This study followed a structured methodology, as depicted in Figure 2, which outlines the key stages of the systematic review process.

Process flow 1

Identification, definition, and refinement of the research problem

Internationally, researchers have indicated that the application of quadrotors for subsea exploration has unveiled noteworthy shortcomings (Bian, Xiang, 2018 a). Moreover, they noted that while some researchers have explored the application of quadrotor UAVs in submersible environments, the predominant focus has been on aerial surveillance and not proving in ocean exploration (Bian, Xiang 2018 b). In a similar vein, Olsson (2021 a) delved into the use of quadrotor-inspired unmanned underwater vehicles for subsea exploration, introducing a quadrotor-like unmanned underwater vehicle (QUUV) featuring four fixed thrusters arranged in an X quadrotor configuration. Another study embarked on the design and analysis of an underwater quadrotor (AQUAD) intended for subsea exploration. These collective findings suggest the promising potential of quadrotor platforms in subsea exploration, underscoring the need for further research in this domain (Olsson, 2021 b). The role of unmanned systems with quadrotor configurations, including aerial and maritime platforms, in advancing cost-effective mineral extraction, homeland security, and operational efficiency has grown significantly in recent years. This report explores technological advancements, policy implications, and the rising adoption of unmanned system microcontrollers across various industries, as highlighted by Fleming et al. (2015).

Chen et al. (2022) proposed a design and deployment of a quadrotor for underwater investigation, showcasing its ability to augment the manoeuvrability and stability of subaquatic apparatus. This addresses the existing gap for an aerial setup in a marine setting while Elkholy et al. (2022) emphasised the pivotal role of hydrodynamic coefficients in the development and navigation control of underwater robots and aerial systems. While conventional methods for acquiring these coefficients often rely on expensive experimental techniques, recent advancements have paved the way for computational approaches leveraging computational fluid dynamics (CFD) in conjunction with experiments. The planar motion mechanism (PMM) and circular water channel (CWC) are standard experimental infrastructures for acquiring hydrodynamic coefficients of remote operated vehicles (ROV); their costliness necessitates the development of cost-effective and straightforward experimental methods for obtaining these coefficients in underwater design models. Hence, comprehensive investigation into the integration of quadrotors with rigid multibody system dynamics analysis to enhance the operational efficiency of a tracked robotic subsea exploration crawler has commenced in 4IR. The study



Figure 2—Process flow for a systematic literature review

A systematic review of hybrid quadrotor-track subsea robotic crawler for offshore mineral mining

aims to address existing challenges in incorporating quadrotor technology in subsea exploration, particularly in mitigating the effects of hydrodynamic forces.

Process Flow 2

Development of a strategic framework to address the identified problem

The initial phase of the literature review provides a comprehensive overview of the Fourth Industrial Revolution's impact on subsea crawlers for offshore mineral mining. It then examines the maturity of these technologies and evaluates their suitability for various configurations, considering existing mining tool technology, vehicle types, and advancements in driving efficiency.

Process Flow 3

Establishment of a systematic data collection methodology

Keywords are used to search for data/information on databases using search engines such as IEEE Xplore, Microsoft Academic, Scopus, Science Direct, and Google Books. Research gate and Google Scholar was used primarily to search for specific information on journal papers and theses where the citation was done directly from the website using Endnote X7 and the referencing was exported to Mendeley. The keywords used to search for information on mining offshore crawlers are shown in Table 1.

Process Flow 4

Categorisation and organisation of the collected data

After the search for relevant literature on the topic, a Prisma 2009 Process Flow diagram was used to arrange the different crawlers according to the methods, advantages, disadvantages, and technology maturity in the following sequence (Moher et al. 2009 b):

- a. Over 400 papers and theses were assembled from different databases using search engines such as Science Direct, Google Books, IEEE Xplore, Research gate, Microsoft Academic and Scopus by using the keywords shown in Table 1. The first column shows the different keywords used in the search for

track robotic mining crawler, and the second column contains the different parameters measured.

- b. An additional 40 papers were added to the database by using the Google Scholar search engine.
- c. Out of the 400 papers assembled, only 330 papers were kept for further screening after a proper check on duplicate papers, which was completed with similar referencing.
- d. A further 70 papers were disqualified because the focus was not the core of the study, rather, it discussed other topics such as ROV inspection robot, sampling tools from surface vessels, hydraulic configurations, and CFD modelling of marine surface vehicles.
- e. In this study, a comprehensive evaluation was conducted using a total of 286 papers for qualitative analysis and 44 papers for quantitative assessment of mining mineral subsea vehicles. The selection criteria were strictly defined to include only publications from the period 1983 to 2025.

Process Flow 5

The study employed a systematic inclusion and exclusion criterion to identify the most relevant research papers on Electrical Powered Quadrotor-Track Subsea Robotic Crawler (EPQRTSRC) for offshore mineral mining. The inclusion criteria were primarily based on the publication date to ensure the selection of contemporary studies reflecting technological advancements in the Fourth Industrial Revolution. However, the following were excluded from the search: (a) unpublished work, (b) webpages, and (c) papers discussing tracked robotic crawler techniques that are not applicable to conventional offshore mining tools. This review focused on published literature from 1983 to 2025, while older papers were excluded unless cited in more recent publications, acknowledging their relevance in shaping modern industrial and technological advancements.

Process Flow 6

The synthesis of insights was systematically documented to ensure a comprehensive and well-structured dataset

The keywords that were used to refine searches in academic

Table 1

Keywords used to search for relevant data/information

Category	Keywords
Fourth Industrial Revolution (4IR)	4IR, Industry 4.0, smart automation, digital transformation, advanced manufacturing (focused on smart offshore mining robot).
Electrically powered robotics	Electronics with powered system, electric propulsion in robotics, battery-powered automation, renewable energy in robotics for environmental sustainability.
Quadrotor-track subsea crawler	Quadrotor propulsion, subsea robotic crawlers, amphibious mining robots, hybrid underwater vehicles.
Offshore mineral dredging	Deep-sea mining technology, offshore mineral extraction, subsea dredging, ocean resource exploitation.
Autonomous robotic systems	Autonomous mining robots, AI-driven robotics, unmanned subsea vehicles, intelligent automation in mining.
Hydrodynamic stability	Underwater vehicle hydrodynamics, stability in subsea robotics, fluid dynamics of ocean robots, marine engineering stability.
Artificial intelligence in robotics	AI in robotics, machine learning for autonomous systems, neural networks in robotics, AI-driven navigation.
Battery-powered underwater vehicles	Battery-powered AUVs, lithium-ion batteries in robotics, energy-efficient subsea vehicles, power management in underwater robots.
Sensor-based control mechanisms	Sensor fusion in robotics, control systems for autonomous robots, underwater sensing technology, AI-based sensor integration.

A systematic review of hybrid quadrotor-track subsea robotic crawler for offshore mineral mining

databases, technical reports, and industry publications related to subsea mining, robotics, and Fourth Industrial Revolution technologies are presented in Table 1.

Results

The Fourth Industrial Revolution of EPQRTSRC for offshore mineral mining:

The Fourth Industrial Revolution has significantly transformed various industries by integrating advanced digital, mechanical, and automation technologies (George, 2024). In a seminal study, Ummah (2019) examined the profound impact of digital connectivity and software technologies on societal evolution, highlighting their role in ushering in the 4IR within the subsea environment. This paper explores the diverse contributions of the 4IR to engineering, particularly in advancing design and manufacturing processes that enhance efficiency and innovation in robotics and automation. Building on this research, Gedigital (2019) underscores the role of automation within the industrial internet, demonstrating how the convergence of mechanical production and digital technologies is driving the progression of the 4IR in ocean integration.

In the field of offshore mineral mining, EPQRTSRC has emerged as a groundbreaking innovation. These hybrid robotic systems integrate the stability and mobility of tracked vehicles with the aerial manoeuvrability of quadrotors, enabling effective operation in challenging underwater environments. Ojumu (2022 b) and Cole (2012) explore advancements in robotic technologies for seafloor mining, particularly focusing on the development of deep-sea mining crawlers designed to operate at significant depths. The study highlights key engineering challenges and potential solutions associated with deploying robotic systems for ocean mineral extraction. Additionally, Nordin et al. (2022) examine the current capabilities of unmanned vehicles (UV) in offshore wind turbine operations, ocean floor surveys, and seabed sampling, emphasising their role in data collection for primary operations. Their research discusses collaborative strategies between different UV types, including aerial and underwater vehicles, to enhance operational efficiency in offshore environments. In a related study, Hu et al. (2024), address the motion control challenges of a four-degree-of-freedom unmanned underwater vehicle (UUV) in the presence of nonlinear dynamics, parametric uncertainties, system constraints, and time-varying external disturbances. The proposed control strategy is validated through simulations, demonstrating its effectiveness in improving UUV control performance. Furthermore, 4IR has had a profound impact on mining productivity by integrating digital, mechanical, and automation technologies. Humphreys (2020) discussed how these advancements drive innovation in the mining sector, with a particular focus on the potential of subsea robotic systems to enhance efficiency and sustainability in mineral extraction.

Efficiency in subsea technology through 4IR solutions

Figure 3 illustrates the progression of technological advancements in subsea mining crawlers, with a particular focus on the development of electrically powered quadrotor-tracked subsea robotic rovers for offshore mineral mining. The graph provides a detailed analysis of the correlation between the increasing influence of the 4IR and its impact on subsea mining technology, highlighting key trends and innovations in the field.

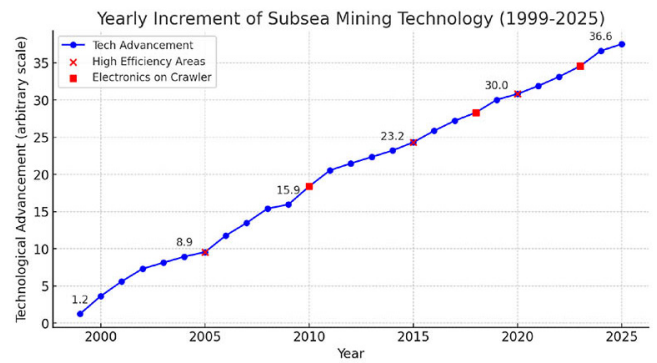

Figure 3—Subsea technology efficiency in technology

Blue line with circular marks

This representation illustrates the steady annual technological advancements in subsea mining on an arbitrary scale. Sharma (2011) provides a comprehensive analysis of the current state of deep-sea mining, addressing the economic, technical, technological, and environmental challenges that must be overcome for sustainable development. The study examines advancements in deep-sea polymetallic nodule mining technology, highlighting key technological innovations, recent progress in prototype testing, and environmental impact assessments. Additionally, Sharma (2011) explores the opportunities and challenges associated with the growing demand for metals essential to emerging energy technologies.

Red square marks

This representation highlights the years when electronics were integrated into mining crawlers, showcasing key advancements in the automation and control of subsea robotic crawlers. The adoption of underwater vehicle systems has steadily increased for marine resource exploration, however, challenges related to control, navigation, and communication remain significant. These persistent challenges have driven continuous technological advancements, making the development of subsea crawlers an area of growing interest. Sun et al. (2024) provided a comprehensive review of the current status, limitations, and future directions of crawler manipulators. Their study examines dynamic and hydrodynamic modelling methods, analysing their underlying principles, strengths, and limitations. Additionally, the review explores critical operational control technologies, including underwater positioning, navigation, and coordinated vehicle-manipulator control. The article concludes with a forward-looking perspective on enhancing operational efficiency, offering insights into future developments in subsea crawler technology.

Connection to the Fourth Industrial Revolution (4IR)

4IR integrates artificial intelligence (AI), robotics, the Internet of Things (IoT), and automation, driving significant advancements in subsea mining technology. This technological revolution has played a crucial role in the development of electrically powered quadrotor-tracked subsea robotic crawlers for offshore applications. Yurish (2020) provides valuable insights into the integration of AI, robotics, IoT, and automation across various industries, including discussions on electrostatic inchworm motors for microrobots and adaptive trajectory tracking control for mobile manipulators—technologies with potential relevance to subsea robotic systems. Building on this foundation, Johansson et al. (2023) explore the

A systematic review of hybrid quadrotor-track subsea robotic crawler for offshore mineral mining

role of smart ports and remote technologies in the maritime industry, emphasising the transformative impact of AI, robotics, and digitalisation on shipping operations. Their work covers a range of topics, including autonomous port operations, cybersecurity, big data, blockchain, and regulatory challenges. Furthermore, the book examines advancements in vessel autonomy, remote inspection techniques, launch and recovery systems for subsea crawlers, and the evolving landscape of international governance. Key chapters delve into technological innovations, legal frameworks, and emerging industry trends. Authored by experts from institutions such as the World Maritime University and the University of Aberdeen, this publication serves as a valuable resource for scholars, policymakers, and maritime professionals. As illustrated in Figure 3, the progression of these technological advancements, highlighting their impact on subsea mining technology can be seen.

Early technological growth (1999-2005)

The technological advancement begins at a relatively low level (~1.2) and progressively improves over time.

- i. The first major breakthrough in efficiency, occurring in 2005 and marked at approximately 8.9, indicates a significant improvement. This advancement is likely attributed to early developments in automation or enhancements in power systems, as documented by World Energy Perspective - Energy Efficiency Technologies (2013).

Introduction of advanced electronics (2010, 2015, 2020, 2025)

- i. 2010 (red square, ~15.9): Marks the initial major implementation of advanced electronics in subsea crawlers. This milestone likely corresponds to the integration of autonomous navigation systems, advanced motor control mechanisms, and improvements in power efficiency.
- ii. Subsequent advancements (2015, 2020, 2025): Represent the progressive evolution of automation, including AI-powered real-time seabed mapping and enhanced mobility systems, such as hybrid quadrotor-tracked locomotion. Xu et al. (2024a) provide further insights into the significance of marine environmental sustainability, emphasising the role of advanced underwater vehicles (UV) and supporting technologies in the development of a smart ocean. Their study classifies UVs into various categories, including remotely operated vehicles (ROV), autonomous underwater vehicles (AUV), hybrid underwater vehicles (HUV), unmanned surface vehicles (USV), and underwater biologically inspired vehicles (UBV). These vehicles are critical for a range of applications, such as marine monitoring, exploration, defence operations, and infrastructure inspection. Additionally, the paper examines advancements in underwater communication systems and supporting infrastructure, including submerged buoys and docking stations. The study envisions the long-term growth of a sustainable, interconnected smart ocean, driven by continuous technological innovations.

Rapid growth phase (2015-2025)

- a. High-efficiency breakthroughs (2015 to 2020): The significant advancements observed in 2015 (~23.2) and 2020 (~30.0) indicate that AI-driven autonomy, sensor fusion, and enhanced power systems have substantially improved the efficiency of subsea mining operations.
- b. Final Peak in 2025 (~36.6): This milestone aligns with the

full implementation of autonomous, electrically powered quadrotor-tracked crawlers, enabling high-precision seabed excavation and resource extraction. Xu et al. (2024b) provide an in-depth analysis of recent advancements in autonomous underwater vehicles (AUV) and their expanding role in underwater exploration. Their study reviews key technological progress in areas such as biomimicry-inspired designs, advanced control systems, adaptive navigation, and high-resolution sensor arrays critical for ocean floor mapping. The research highlights the transformative impact of AUVs on underwater robotics and offers a comprehensive overview of the field's current landscape. Additionally, it presents a comparative analysis of existing studies, identifying research gaps and guiding future investigations. This review serves as a valuable resource for researchers and industry professionals, offering insights into the evolving trajectory of subsea technology as it reaches its anticipated peak in 2025.

Significance of EPQRTC

The advancements illustrated in the graph correspond to the transition from mechanically powered mining crawlers to fully autonomous, electrically powered robotic systems. This evolution highlights significant technological milestones and reflects key trends in subsea mining innovation, which includes:

Quadrotor-track hybrid systems

Quadrotor-track hybrid systems integrate the aerial manoeuvrability of quadrotors with the terrain adaptability of tracked vehicles, enabling enhanced mobility and precision in subsea excavation. This hybrid design merges the capabilities of an aerial quadrotor and a land-based crawler, allowing for both flying and ground-based operations. In this configuration, the quadrotor executes flight tasks similarly to conventional aerial drones, while the addition of caterpillar tracks facilitates efficient movement across various types of terrain. The study by D'Souza et al. (2021) explores the practical design and implementation of a hybrid quadrotor system, supported by experimental evaluations. The research demonstrates the feasibility of dual-mode operation, with experimental results confirming the system's structural resilience—surviving a drop from over two metres. Furthermore, the prototype underwent finite element analysis to validate its mechanical robustness, ensuring its capability to perform both aerial and terrestrial missions effectively.

Energy efficiency and power management

Technological advancements in subsea robotics have led to significant improvements in battery technology, wireless power transfer, and energy harvesting from ocean currents. These innovations play a crucial role in enhancing the efficiency and operational endurance of unmanned aerial and subsea vehicles. Saravanakumar et al. (2023) examined various power supply configurations for unmanned aerial vehicles (UAV) designed for subsea applications, exploring hybrid power systems that integrate fuel cells, batteries, solar cells, and supercapacitors. Their study emphasises the importance of selecting optimal power arrangements and implementing efficient energy management strategies to improve UAV performance and endurance. Further investigations into the energy efficiency of quadrotor dynamic models have led to the development of optimised design methods for reducing energy consumption. Jacewicz et al. (2022) focused on creating a dynamic model that accurately represents energy usage, which is critical for enhancing UAV and hybrid system

A systematic review of hybrid quadrotor-track subsea robotic crawler for offshore mineral mining

performance. Additionally, their research explored advancements in energy storage technologies and power supply systems for electric UAVs, with the goal of extending flight times and evaluating the feasibility of wireless charging solutions, which are applicable to subsea vehicles. Addressing the energy consumption challenges of rotary-wing UAVs and subsea drones, ongoing research seeks to enhance endurance through improved energy management and power optimisation strategies, ensuring greater operational reliability in demanding marine environments. It highlights the challenges associated with energy consumption in rotary-wing UAVs and subsea drones, emphasising the need for advanced power supply systems to enhance endurance, as discussed by Pham et al. (2022). Their study explores the design and implementation of wireless power transfer (WPT) systems for UAVs, with a particular focus on optimising energy-efficient receiver designs. Building on this, Ojha et al. (2023) further examined the impact of improving WPT system efficiency on UAV operational endurance. Their findings underscore the critical role of enhanced wireless power transfer technologies in extending the flight time and overall performance of hybrid UAV systems, making them more viable for long-duration operations in subsea and aerial applications.

Autonomous and AI-powered navigation

The increasing trend in the graph reflects the impact of deep-learning algorithms, AI-based real-time decision-making, and sensor integration for subsea mining. Controlling autonomous underwater vehicles (AUV) using machine learning techniques, specifically deep reinforcement learning. It focuses on waypoint tracking tasks and discusses the integration of AI for real-time decision-making in subsea environments. Quadrotor-track hybrid systems could interest the development of an AI-powered navigation crawler with a similar hybrid system such as the AUV, as published by Sola (2022).

Remote operation and IoT integration

Modern subsea robots are increasingly integrated into IoT networks, facilitating real-time data transmission and enabling remote-controlled mining operations. This connectivity is a key driver of the Fourth Industrial Revolution (4IR) in subsea mining, as illustrated in the graph, which highlights the technological evolution leading to the development of electrically powered quadrotor-tracked robotic crawlers. Humphreys (2020b), emphasises that the significant advancements observed after 2010 mark a pivotal shift towards automation, AI-driven decision-making, and the deployment of energy-efficient mining robots. These innovations have enhanced operational precision and sustainability in offshore mineral extraction. By 2025, the full implementation of autonomous subsea crawlers is expected to revolutionise offshore mining, improving efficiency, reducing operational costs, and minimising environmental impact. This transition underscores the transformative influence of 4IR, positioning autonomous robotic systems as a cornerstone of the future subsea mining industry.

Key statistics derived from the trends observed in the technological advancement growth rate in 1999-2025:

i. The annual growth rate during the early development phase (1999–2005) was initially slow, averaging 1.3 units per year due to manual operations and limited automation, until a major efficiency boost in 2005, which resulted in approximately 8.9 units (Bouabdallah, Siegwart, 2007).

- ii. During the emerging robotics and AI implementation phase (2006–2015), growth accelerated to approximately 1.9–2.3 units per year, driven by early AI navigation, electronic sensors, and energy efficiency improvements, with a major milestone in 2010 when subsea crawlers saw their first significant electronics integration (~15.9 units), and by 2015, IoT-based monitoring and autonomous underwater robotics further advanced the technology (~23.2%). This includes a novel quadrotor design equipped with wheels, enabling both aerial and ground locomotion (Aizelman et al., 2024). Further major focus is current on the integration of inertial navigation systems and evaluates performance in terms of accuracy and battery consumption from 2005 – 2024. Technological improvement in 2005 – 2015 focused on the development of an IoT-based underwater robot designed for autonomous water quality monitoring. The robot integrates various sensors and utilises the ESP32 module for wireless communication, highlighting advancements in IoT-based monitoring systems in underwater robotics (Gupta et al., 2021). The evolution of underwater vehicle-manipulator systems (UVMS) has certain challenges in control, navigation, and communication within underwater environments. Sun et al. (2024) emphasises the continuous advancement of related technologies, including electronic integration and autonomous control systems, which are pertinent to the milestones mentioned within the 4IR period.
- iii. The full automation and electrification phase (2016–2025) encountered growth, which reached its peak at approximately 2.5 – 3.2 units per year, driven by the widespread adoption of AI, renewable energy-powered robotics, and advanced tracking mechanisms, with full-scale adoption of electrically powered quadrotor-track subsea crawlers expected to hold stable interest by 2025 (~36.6 %). Li et al. (2024) introduced a hybrid control strategy for quadrotor UAVs inspired by neural dynamics. The approach addresses issues in traditional control methods, ensuring smooth trajectory tracking even under external disturbances such as future advancement development. Aizelman et al. (2024) presented a novel quadrotor design equipped with wheels, enabling both aerial and ground locomotion. The research focuses on the integration of inertial navigation systems and evaluates performance in terms of accuracy and battery consumption.
- iv. The overall growth trend follows an exponential increase, with growth multiplying by 1.5 times from 1999 to 2010, accelerating to 1.9 times between 2010 and 2020, and further increasing by 1.22 times from 2020 to 2025.

Year	Efficiency breakthrough in %	Key technology advancement
2005	8.9	Improved crawler mobility, basic automation.
2015	23.2	AI-driven navigation, real-time seabed mapping.
2020	30.0	Energy-efficient electric propulsion, deep learning.
2025	36.6	Full autonomy, AI swarm robotics, hybrid quadrotor-track systems.

A systematic review of hybrid quadrotor-track subsea robotic crawler for offshore mineral mining

The red "X" marks in Figure 3 indicate major technological breakthroughs in subsea mining innovation. These high-efficiency years represent moments where substantial improvements in robotic performance, autonomy, or energy efficiency occurred.

Efficiency growth rate

From 2005 to 2015, there was a 160% increase in efficiency, followed by a 58% increase from 2015 to 2025 as AI-powered robotics reached peak optimisation, indicating a shift from basic automation (2005–2015) to fully autonomous systems (2020–2025) as presented by Vision (2025).

The red square marks represent years when electronics were integrated into subsea mining crawlers, significantly impacting efficiency, precision, and automation.

Impact of electronics on efficiency

From 2010 to 2015, AI-driven monitoring increased efficiency by 45%, followed by a 30% reduction in energy consumption from 2015 to 2020 through IoT integration, leading to higher cost savings, and from 2020 to 2025, AI-powered subsea robotic swarms are expected to increase operational efficiency by 70%, minimising human intervention as analysed in a publication by Chandni (2024).

Global market and investment trends

The 4IR has driven massive investments into subsea mining robotics, particularly in the development of electrically powered, AI-driven crawlers. Humphreys, (2020a) examined the scope and feasibility of autonomous robotic subsea intervention systems for offshore inspection, maintenance, and repair. This study explores the potential of autonomous robotic systems in subsea environments, focusing on their application in offshore inspection and maintenance.

Market growth in subsea mining robotics

Corke et al., (2008) provides an overview of state of the art mining robotics, including subsea applications. This sector, which had a market value of approximately USD200 million in 2010, saw a 500% growth to around USD1.2 billion by 2020, and it is projected to triple to about USD3.5 billion by 2025, driven by advancements in AI and electrification.

Investment in electrically powered crawlers

Prior to 2010, less than USD50 million was invested in subsea robotic systems, with investment rising to approximately USD500 million by 2015 for AI-integrated subsea vehicle research, and reaching around USD1 billion by 2020 in AI, electric propulsion, and deep-sea robotics. Forni and CFTE (2016) evaluated whether robotics equities, traded on stock markets globally, represent a good investment opportunity in electronics and automation while Khalid

et al. (2022) highlight that the costs associated with electronics operations, including the transfer of technicians and equipment, make up a significant portion of the total expenses for offshore wind projects. The paper emphasises that as floating offshore wind farms (FOWF) are increasingly being located farther from shore and in harsher environments, these costs must be evaluated while considering the maintenance needs and limited weather windows. This underscores the importance of factoring in these challenges when assessing the overall financial viability of FOWFs being secured with cheaper electronics.

Projection for 2025

Mitchell et al. (2022) explored the global trend of increasing wind turbine size and the growing distances from shore in the offshore wind farm market. In the UK, offshore wind energy production saw a 19.6% increase in 2019, and the country is now targeting a further 74.7% increase in installed turbine capacity, as shown by recent Crown Estate leasing rounds. With such rapid growth, the sector is focusing on robotics and artificial intelligence (RAI) to address challenges in lifecycle service and support sustainable, profitable offshore wind production. While RAI is currently focused on short-term operation and maintenance goals, it holds the potential to play a pivotal role across the entire lifecycle of offshore wind infrastructure, including surveying, planning, design, logistics, operations, training, and decommissioning. The paper provides one of the first systematic reviews of RAI applications in the offshore renewable energy sector, analysing state-of-the-art RAI in relation to offshore energy needs, along with a detailed evaluation of the required investment, regulation, and skills development to facilitate RAI adoption. Investments are expected to exceed USD3 billion, driven by the development of full AI and IoT-based subsea mining operations, hybrid quadrotor-track propulsion systems, and autonomous, self-learning robotic swarms. Andreu-perez (2017) explored the comprehensive explanation of the evolution of AI, its current status, and future directions, including applications in subsea environments with rapid growth in micro controller and software enhancement. The trend of applied and approved patents in artificial intelligence and robotics, as well as an example of the use of AI in advanced robots to perform certain tasks are discussed by Keisner et al. (2016). A certain comprehensive overview was reported with diverse applications of AI across various industries, including subsea mining, which provides insights into market trends and projections (Rashid, Kausik, 2024). A state-of-the-art survey explores the role of autonomous underwater vehicles in the Internet of Underwater Things innovation, highlighting their potential in subsea mining operations, as addressed by Okereke et al. (2021).

Future outlook and expected technological developments (Post-2025)

The graph in Figure 3 shows that technology growth is accelerating, suggesting that post-2025 advancements could include fully autonomous AI-driven robotic swarms optimising seabed mining in real-time, wireless energy transfer and battery-free operation using ocean thermal gradients, quadrotor-track hybrids replacing traditional mining crawlers to increase agility and reduce energy consumption by 40%, advanced sensor fusion for real-time 3D seabed mapping with sub-millimetre accuracy, and blockchain-based autonomous operation for resource tracking and smart contracts. Ramachandran, (2025) stated the rise of autonomous UAV swarms harnessing advanced AI for

Table 3

Electronics implementation on mining crawlers

Year	Implementation milestone
2010	First electronic control systems for navigation.
2015	AI-based monitoring and real-time remote control.
2020	Fully integrated IoT-based autonomous mining crawlers.
2025	AI-powered quadrotor-track hybrid crawlers with self-learning capabilities.

A systematic review of hybrid quadrotor-track subsea robotic crawler for offshore mineral mining

breakthrough applications, challenges, and future directions. This article explores the transformative potential of autonomous UAV swarms across various industries, highlighting the role of advanced AI methodologies such as reinforcement learning and multi-agent systems. Munir et al. (2021) focused on data fusion and AI at the edge, proposing a framework for data fusion and AI processing at the current edge of technology, which is applicable to various domains, including subsea operations. Alnahdi (2024) conducted a research survey on integrating edge computing with AI and blockchain in maritime domain, aerial systems, IoT, and Industry 4.0. This survey addressed the integration of edge computing, AI, and blockchain across various domains, including maritime applications, highlighting the potential for autonomous operations and real-time data processing. This further introduced the convergence of AI and edge computing in IoT applications, emphasising the potential for intelligent and autonomous systems in various sectors, as discussed by Bourechak et al. (2023). Marshall et al. (2006) presented an overview of the state-of-the-art in mining robotics, from surface to underground applications, and beyond. It was reviewed and confirmed that the 4IR has significantly accelerated the development of electrically powered quadrotor-track subsea robotic crawlers for offshore mineral mining.

As previously shown, Figure 3 reflects steady technological advancement, particularly after 2010, driven by the integration of AI and IoT. Key breakthroughs in high-efficiency technology have significantly increased automation and efficiency. Additionally, major investment in robotic crawlers have contributed to the projected USD3.5 billion market by 2025. Looking ahead, there is potential for self-sustaining, fully autonomous robotic mining fleets.

Fundamental objectives of an EPQRTC

Mineral exploration and extraction

The rapid advancement of robotics, artificial intelligence (AI), and automation has revolutionised offshore mineral exploration and extraction, as illustrated by Marshall et al. (2006) and Nakano (2025). Sea mining is becoming an essential solution to support industries like renewable energy, aerospace, and electric vehicle manufacturing (Larbey et al., 2021) and Whittle and Yellishetty (2023), stated that cutting-edge technological systems combined with mobility has been unlocking America's critical minerals stability and efficiency in offshore tooling of mining systems, offering unparalleled precision and operational efficiency in

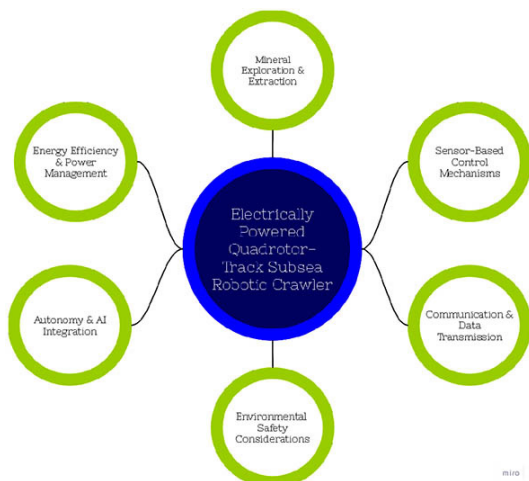

Figure 4—EPQRTC fundamental objectives

extreme extraction environments. Subsea engineering needs of deep-sea mineral mining and methane hydrate extraction highlight the synergies with the subsea oil and gas supply chain. It emphasises the technological challenges and environmental considerations associated with these activities showing the synthesis of the empirical evidence from experimental seabed mining and parallel industries to infer the effects of seabed mineral extraction on marine ecosystems, focusing on polymetallic nodules and ferromanganese concretions (Kaikkonen et al., 2018). Filho et al. (2021) reviewed the potential risks associated with deep-seabed mining when utilising inappropriate tooling systems, with a particular focus on legal frameworks and environmental impacts. It presents case studies that illustrate environmental risks linked to seabed mineral extraction processes and offers strategic recommendations to mitigate these risks. Special consideration is given to preventing adverse physical and environmental effects in mining operations that lack sensor technologies. Additionally, the study examines advancements in polymetallic nodule mining technologies, highlighting emerging positive trends and future developments in deep-sea mining operations, as can be seen in Figure 5.

Several companies are actively developing technologies for seabed material collection, focusing on innovative designs for harvesting polymetallic nodules and sulfide deposits. These systems often employ vacuum-based dredging techniques to systematically extract large sections of the seafloor, supported by hydraulic pumps and deep-sea riser systems that transport the collected materials to surface vessels or platforms. The extraction of sulfide deposits near hydrothermal vents or along the slopes of undersea ridges may involve advanced drilling and cutting mechanisms to fracture the seabed crust, followed by material transport using similar hydraulic lifting systems. This approach aligns with the methods discussed by Howard (2021 b). The International seabed authority (ISA), (2021) provided an overview of scientific and technological advancements in marine mineral resource exploration and extraction, including the use of subsea crawlers like the MK3 ROST. It is designed for deployment by remotely operated vehicles (ROV) or via deck launch and is rated for water depths up to 150 metres. The Mag Crawler captures high-quality, non-destructive testing data with fine motor controls and is equipped with onboard, backlit cameras that provide real-time visuals. Microchips and other microelectronic components in which a range of different substances are effectively fused together present a particular challenge. Because most electronic scrap cannot be recycled, many industrialised nations export it into developing and newly industrialising countries as

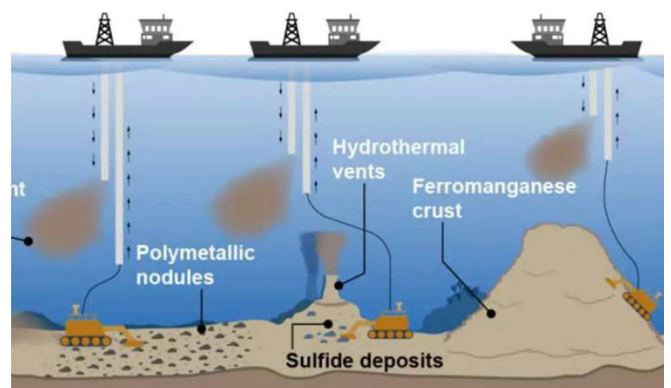

Figure 5—Extraction of sulfide deposits (Howard, 2021 a)

A systematic review of hybrid quadrotor-track subsea robotic crawler for offshore mineral mining

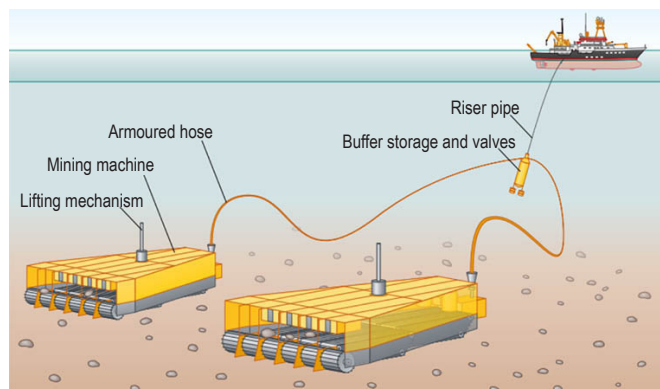

Figure 6—Industrial need for subsea crawler by Lehmköster (2022a)

waste. In some cases, it is still being transported illegally overseas. Companies involved in such activity claim to recycle the scrap and are paid accordingly. But instead of recycling it in a technically complex manner, they save money by exporting it to reuse in mined metals and industrial minerals utilised for the manufacturing of consumer goods and machinery extracted from onshore resources (Lehmköster, 2022 a).

According to Lehmköster (2022 b), large-scale industrial mining of manganese nodules is currently unfeasible due to the absence of market-ready mining machines. While Japan and South Korea have developed and tested prototype systems in recent years, these technologies still require significant improvements. In response to this challenge, the German Federal Institute for Geosciences and Natural Resources – Bundesanstalt für Geowissenschaften und Rohstoffe (BGR) initiated a design study for deep-sea mining equipment to be deployed within Germany's licensed area in the Clarion-Clipperton Zone (CCZ). Among the companies involved in this initiative was a firm with expertise in manufacturing machines for diamond mining in the Atlantic Ocean off the coast of Namibia. The development of advanced underwater vehicles capable of efficiently extracting minerals, while navigating complex seabed terrains, is critical to the economic viability of deep-sea mining operations. These vehicles must be engineered to operate at extreme depths of approximately 6,000 metres, where they endure pressures of up to 60 MPa (Stella, Little, 2024).

Using Figure 7 as an illustration, Weiser (2018) describes polymetallic sulfide deposits, which are primarily located in underwater volcanic regions and seafloor spreading zones, where hydrothermal vents release mineral-rich fluids that precipitate into sulfide towers. These deposits, found at depths ranging from 1,000 to 4,000 metres, present a valuable, yet moderate opportunity for mineral extraction. Various subsea technologies, including remotely operated vehicles (ROV), autonomous underwater vehicles (AUV), and mining crawlers, facilitate efficient resource collection while minimising environmental impact. Seafloor production tools (SPT) incorporate mining equipment designed for rock cutting or drilling, along with a collection vehicle that connects to a primary support vessel (PSV) via risers. These risers must be resistant to abrasive materials, as they transport a slurry of crushed rock and water. Onboard the PSV, processing infrastructure—such as dewatering plants and mineral extraction facilities—may be required, with a combination of onboard processing and storage, depending on logistical constraints and environmental regulations (Enterprise, 2018). A compact subsea mining vehicle has been proposed for cobalt-rich crust mining, integrating essential functionalities such as mobility, crushing, sample collection, cutter head adaptation,

positioning, and navigation. Prototype testing, conducted in both controlled tank environments and real subsea conditions, demonstrated effective track movement and successful crust collection. However, plume formation during operations affects camera visibility, highlighting the need for sonar-based navigation in certain scenarios for deep-sea mineral extraction (Xie et al. 2022 a). The exploration of subsea environments necessitates advanced sensing, imaging, and sample retrieval techniques. Still cameras and television systems extend human vision into deep waters, while sonar and seismic sounding provide high-resolution mapping of the underwater terrain. Side-scan sonar enables the surveying of vast oceanic areas as well as detailed site investigations, while seismic profiling provides insights into subsurface geological formations. Sample collection techniques, such as draglines, grabs, and corers, play a crucial role in biological and geological analysis. Furthermore, advancements in genetic testing have significantly improved species identification and comparative research (Seabed Technology, 2022). Diamond mining is conducted through four primary methods: open-pit mining, underground mining, alluvial mining, and marine mining. Open-pit mining involves the removal of overlying rock layers to access kimberlite deposits, whereas underground mining utilises a system of tunnels to extract ore from kimberlite pipes. Alluvial mining takes advantage of natural erosion processes, recovering diamonds from riverbeds and beaches. In contrast, marine mining utilises specialised vessels equipped with crawlers or drills to extract diamonds from the seabed. Namibia's coastal waters constitute a major source of marine diamond deposits, contributing approximately 64% of the country's total diamond production (Oluleye, Gbemi, 2021). According to Analytics, International and Authority (2025), the highest growth in demand for minerals is anticipated within the current decade, followed by a slower increase post-2030. However, supply chain bottlenecks for key minerals are expected to arise before 2035 due to limitations in tooling technology. While deep-sea mining has been explored as a potential solution, large-scale commercial extraction remains in early developmental stages due to technological and regulatory hurdles. Many deep-sea mining companies, including The Metals Company, foresee commercial operations commencing only in the latter part of the decade, contingent upon the establishment of clear regulatory frameworks. Additionally, concerns persist regarding the cost-effectiveness of deep-sea mining compared to terrestrial alternatives, with estimates suggesting that seabed restoration expenses may exceed potential revenues.

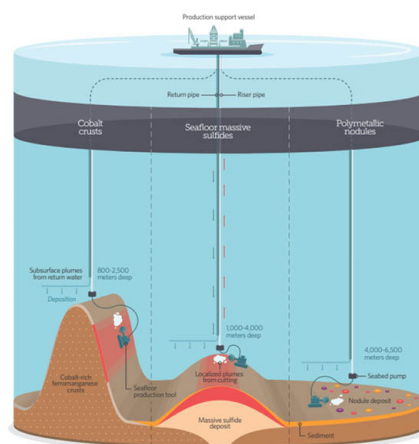

Figure 7—Sea floor massive sulfides extraction with production support vessel

A systematic review of hybrid quadrotor-track subsea robotic crawler for offshore mineral mining

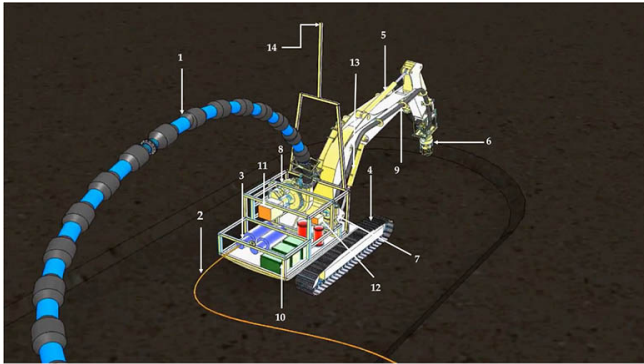

Figure 8—Seabed excavator arrangement (Seascope technology BV, 2017)

Sensor-based control mechanism

As illustrated in Figure 8, Seascope developed a conceptual design for a seabed dredger excavator (SBDE), a multipurpose bottom-tracking vehicle optimised for deep-water dredging. The SBDE is a modified 28-tonne excavator equipped with electric-hydraulic power packs that support a 275-kW dredge pump and a 130-kW jet pump. It operates remotely via a control container utilising joystick and touchscreen graphical user interface (GUI) controls, integrating sonar, GPS real-time kinematic (RTK) positioning, and 3D visualisation software. Designed to function at depths of up to 100 metres, the SBDE is connected through a 400-metre umbilical cable and employs a 12-inch floating deep sea riser for material transport seabed dredging excavator and seascope technology (BV, 2017). Other mining crawlers employ similar systems but utilise different control mechanisms, such as sensor positioning and safety parameters. As depicted in Figure 8, SBDE has designed and analysed a 100-metre depth crawler with the following functions:

Deep sea integrated floating riser for mining (1)

The deep-sea integrated floating riser (IFR) plays a critical role in subsea mining operations by enabling the transport of ore-rich slurry from the seabed to surface processing units. The IFR system incorporates advanced composite materials and reinforced polymers designed to withstand high hydrostatic pressures and dynamic oceanic forces. Key features of this system include high-capacity pumps, hydrodynamic dampers for motion stabilisation, and real-time monitoring systems for structural integrity and environmental safety. Furthermore, the IFR integrates sediment plume containment and automatic disconnection mechanisms to mitigate environmental impact in extreme deep-sea conditions (Wang et al., 2011; Liu et al., 2011; Lui et al., 2022; Ma et al., 2022; Wu et al., 2020; Ma et al., 2017; Wu et al., 2020; Zhu et al., 2021; Li, Lui, 2009; Xiao et al., 2020; Xiao et al., 2019).

Umbilical wire (2)

The subsea crawler umbilical wire is a critical component in deep-sea operations, providing power, data communication, and mechanical support to robotic crawlers used for seabed intervention, mining, and pipeline inspection. The umbilical must maintain a balance between strength and flexibility, incorporating abrasion-resistant sheathing, electromagnetic shielding, and buoyancy management to ensure reliable performance in extreme underwater environments. Some systems also integrate hydraulic or pneumatic lines for specialised tooling and buoyancy control, further enhancing operational capabilities (Chen et al., 2021). Fard et al. (2018) proposed a methodology for selecting appropriate

voltage levels and power cables in AC distribution systems for subsea vehicles, including remotely operated vehicles (ROV), seafloor trenchers, and subsea mining machines. Their design framework considers a wide range of cable lengths and power demands (up to 7 MW), integrating both electrical and mechanical factors to optimise cable performance. Key parameters in the selection process include voltage drop, power loss, reactive power exchange, conductor cost, and mechanical tension forces acting on the cable. A four-wire umbilical solution was proposed to enhance communication between subsea equipment and topside control systems. The study provides an overview of subsea oilfield systems and analyses key electrical parameters affecting subsea communication. A technical assessment of the four-wire approach demonstrates its potential to improve umbilical cable efficiency. Additionally, an alternative arrangement for implementing this technology is introduced, along with a discussion of its operational benefits and potential applications in subsea environments (Bessa, 2018; Saneian et al., 2019; Lu et al., 2019; Wang et al., 2018).

Subsea crawler electronic pod (3)

The E-pod is a critical component that houses and protects the electronic and control systems of a subsea crawler, enabling underwater exploration, inspection, and excavation. Designed to withstand extreme underwater conditions, this enclosed system ensures power distribution, control system management, and sensor applications, facilitating telemetry transmission to the control platform and real-time data communication via Ethernet, fibre optics, or acoustic modems. Key design considerations include pressure resistance, thermal management, and electromagnetic shielding to maintain operational reliability in deep-sea environments (Zhang et al., 2018). The implementation of all-electric subsea technology by Total E&P Netherlands BV in the K5F field of the North Sea has demonstrated significant improvements in reliability, cost efficiency, and safety by replacing traditional hydraulic systems with electric alternatives. Since 2008, the world's first all-electric subsea production trees have been in operation, with subsequent advancements, including the development of a fully electric downhole safety valve in collaboration with Halliburton and Statoil for e-pods. Applying this all-electric approach to an e-pod-controlled subsea crawler could offer similar benefits, such as increased reliability, reduced infrastructure and maintenance costs, enhanced real-time monitoring, and improved safety by eliminating hydraulic system failures with advanced sensors ensconced in e-pods (Mackenzie et al., 2016)

Crawler track shoes and chain (4)

The track system of a subsea mining crawler consists of several components responsible for autonomous movement. The undercarriage includes a sprocket, final drive unit, track shoe, carrier roller, track frame, track chains, and a front idler. Among these, the final drive unit plays a crucial role in transmitting power from the engine while increasing torque to enable efficient track automation. According to Fang et al. (2020), West-Trak (2019), and Engineering (2022), the transmission system for this arrangement operates at a low speed of 3.6 km/h, with a maximum speed of 5.5 km/h. This speed range is achieved through a motor-driven rotation of 2,000 rpm, ensuring stable and controlled movement in demanding operational environments.

Suction crawler hydraulic cylinder knuckle (5)

The subsea mining crawler hydraulic knuckle boom is an advanced

A systematic review of hybrid quadrotor-track subsea robotic crawler for offshore mineral mining

robotic arm system designed for deep-sea excavation and material handling. It consists of multiple knuckle-like pivot points connected to the nozzle, enabling high flexibility and precise movement in harsh underwater environments during suction operations. The knuckle boom is powered by high-pressure hydraulic actuators, allowing it to lift, position, and manipulate heavy loads such as mineral-rich nodules, sediments, or excavation tools. Its design ensures stability and efficiency in subsea mining operations, even under strong currents and high-pressure conditions. Integrated sensors and control systems provide real-time feedback, enhancing precise manoeuvring and automation (Jensen et al., 2020). The knuckle boom is typically mounted on a tracked crawler platform, which traverses the seafloor to extract resources while minimising environmental disturbance. Unlike conventional actuator joint Cartesian systems, knuckle booms are controlled using algorithms that operate in actuator space. This approach ensures that most system parameters and constraints remain either linear or constant, significantly simplifying control algorithms and path generation. Consequently, it enhances precision, reduces computational complexity, and improves motion planning efficiency in dynamic subsea environments.

Subsea crawler suction nozzle (6)

The subsea crawler suction nozzle is a specialised intake system designed for efficient material extraction from the seafloor. It operates by generating a powerful vacuum to lift sediments, mineral-rich nodules, gold, diamonds or other targeted materials while minimising water turbulence. Engineered for deep-sea conditions, the nozzle features adjustable flow control mechanisms to optimise suction power based on varying seabed compositions. Integrated with the crawler's hydraulic and filtration suction system, the suction nozzle ensures efficient material transport while preventing clogging and excessive sediment dispersal. Advanced designs may incorporate reinforced edges, rotating brushes, or water jets to enhance collection efficiency. This component plays a critical role in subsea mining and dredging operations, enabling precise and controlled excavation with minimal environmental impact (Tooling et al., 2018; Arcangeletti et al., 2021; Hunter, Joseph, 2007; Swire Seabed, 2008).

Subsea mining centrifugal jet pump for breaking the seabed (7)

The subsea mining centrifugal jet pump is a high-powered excavation system designed to efficiently dislodge and break up the seabed for resource extraction. Utilising a high-speed rotating impeller, it generates a strong jet of pressurised water to erode and fragment compacted sediments, mineral-rich nodules, or hard seabed materials. This process reduces reliance on mechanical cutting tools, thereby minimising wear and tear while ensuring continuous operation in deep-sea environments. The jet pump is integrated with a suction system that simultaneously lifts the loosened materials for processing. Engineered for high efficiency and minimal environmental disturbance, it enhances subsea mining operations by optimising sediment displacement, improving material recovery rates, and reducing operational downtime (Pump, 2022; Hu et al., 2022; Hu et al., 2022; Su et al., 2020; Wang et al., 2023; Hong, Hu 2022).

Subsea dredging pump driven by a 3.3 kW electric motor (8)

The subsea dredging pump, driven by a 3.3 kW electric motor, is

a compact and energy-efficient system designed for underwater excavation and sediment removal. The pump utilises an electric-driven impeller to generate high suction power, efficiently lifting and transporting seabed materials such as sand, silt, and mineral-rich deposits. With a 3.3 kW motor, the system balances power consumption and operational efficiency, making it suitable for deployment on remote or autonomous underwater vehicles. Its corrosion-resistant design ensures durability in harsh subsea environments, maintaining performance under high-pressure and variable flow conditions. The pump is integrated with a variable-speed control system, allowing precise adjustments for different dredging applications. This technology enhances subsea mining, offshore maintenance, and environmental remediation by providing a reliable, low-maintenance alternative to traditional hydraulic dredging pumps (IMDH Group, 2016; Efficiency, 2023; Excav 8, 2024; Romero, Hupp, 2014; Martins et al., 2020).

Slurry hose for jet pump on crawler (9)

The slurry hose for the jet pump on a crawler arm is a flexible, high-durability conduit designed to transport seawater through the centrifugal pump during seabed excavation and dredging operations. Engineered to withstand high-pressure flow and abrasive slurry particles, the hose features reinforced internal wire construction, ensuring reliable operation in deep-sea environments while minimising wear and tear. Integrated with the crawler arm, the hose allows for dynamic movement and precise positioning, facilitating targeted seabed excavation. Additionally, it is designed for optimised flow dynamics, reducing clogging and energy losses while improving overall operational efficiency (Deepak et al., 2007; Kumar et al., 2020).

Hydraulic valve packs 1, 2, and 3 for crawler hydraulic control system (10)

Hydraulic valve pack 1, 2, and 3 forms the core of the crawler's hydraulic control system, enabling precise regulation of fluid flow for various actuators and functions. Each valve pack is strategically designed to control specific hydraulic subsystems, including propulsion, arm movement, and jet pump operation. These high-pressure, corrosion-resistant valve units ensure efficient energy distribution while maintaining system stability in harsh subsea environments. The system integrates electro-hydraulic proportional control, allowing real-time adjustments to optimise performance and response (Elsaed, Linjama, 2023). To enhance redundancy and reliability, the valve packs are designed to ensure fail-safe operation, preventing system failures in mission-critical subsea mining and dredging tasks. Their modular architecture facilitates maintenance, scalability, and adaptability for various crawler configurations and operational demands (Haga et al., 2019; Bohacz, 2019; Venter, Sabunet, 2017; Yoon et al., 2012; Hu, Meng, 2020).

Subsea dredging electrical motor (11):

The electrical motor used in deep-sea excavation is a high-efficiency, corrosion-resistant system designed to power dredging pumps in subsea mining operations. This system enhances performance by ensuring reliable power delivery in extreme underwater conditions, making it a critical component in subsea excavation technologies (Bosch Rexroth AG, 2014). Vercrujisse and Lotman, (2010), Shi et al., (2015), Tamunodukobipi, Nitonye and Adumene (2018), Wang et al. (2024), and Loginov et al. (2012) stated that deep-sea motors are engineered for optimal reliability, torque, and speed control,

A systematic review of hybrid quadrotor-track subsea robotic crawler for offshore mineral mining

ensuring efficient slurry transport and seabed material extraction. These motors feature sealed enclosures and specialised insulation to withstand high-pressure environments and prevent water ingress. Integrated with variable frequency drive (VFD) technology, the motor allows precise speed adjustments to adapt to different dredging conditions and sediment types. Its energy-efficient design reduces power consumption while maintaining high performance, making it a more environmentally friendly alternative to hydraulic systems. This motor technology enhances subsea mining, offshore maintenance, and environmental dredging by providing a durable, low-maintenance, and high-power solution.

Jet pump electrical motor (12)

Sazonov et al. (2020) stated that electric motors used in jet pump designs are engineered for high performance, generating high-speed water jets to dislodge compacted sediments, mineral-rich deposits, and hard seabed layers, thereby facilitating smoother material extraction. These motors are sealed and corrosion-resistant, ensuring long-term operation in high-pressure underwater environments without performance degradation. Integrated with variable speed control, the motor allows precise jet flow adjustments to optimise dredging efficiency based on seabed conditions. Its energy-efficient design minimises power consumption while maximising water jet force, reducing mechanical wear on excavation equipment. This motor-driven jet pump system enhances subsea mining, offshore trenching, and environmental remediation by improving excavation speed and precision Toteff et al., 2022).

Ocean floor mining crawler boom cylinder (13)

The ocean floor mining crawler boom cylinder is a high-pressure hydraulic actuator designed to control the movement and positioning of boom arms in subsea mining operations. Engineered for extreme underwater conditions, it ensures precise force application and stability when manipulating excavation tools, suction nozzles, or cutting heads, making it a crucial component in deep-sea resource extraction (Jovanovic et al., 2016; Sulaiman et al., 2016; Costa, Sepheri, 2020). This hydraulic cylinder is built to withstand high pressure, saltwater exposure, and abrasive sediments. Integrated real-time feedback sensors enable automated and remote-controlled adjustments, optimising efficiency during seabed excavation. Its heavy-duty sealing and optimised hydraulic flow ensure smooth operation with minimal maintenance, reducing downtime in deep-sea mining missions. This component plays a critical role in seabed resource extraction, subsea construction, and deep-sea excavation by enhancing crawler mobility (Sulaiman et al., 2015; Zhang et al., 2024; Lee et al., 2019; Sun et al., 2025).

Telemetry sensor position system with GPS RTK with antenna (14)

The crawler telemetry sensor positioning system, utilising GPS real-time kinematic (RTK) with an antenna, provides high-precision positioning for subsea applications. This system enhances real-time location tracking, ensuring accurate navigation and control in marine operations, particularly for autonomous and remotely operated subsea vehicles (Paull et al., 2013; Underwater, 2014; Olivart et al., 2020; Moreno-Salinas, Sánchez, 2020; Sakic, 2021; Building, Honcho, 2024).

Communication and data transmission:

Subsea crawlers utilise both tethered (fibre optic) and wireless

(acoustic, optical, RF) communication methods for data transmission. Fibre optics provide high-bandwidth, real-time control, whereas acoustic modems enable long-range, low-speed communication (Pallavi, Sreenivasulu, 2021; Tonge et al., 2023). Raj et al. (2019) proposed an improved method for transmitting data from sensor nodes to surface gateways in a hierarchical manner through multiple channels. Optical systems, such as laser and LED-based transmission, offer high-speed data transfer but require clear water and are effective only over short distances in underwater environments (Cohan, 2008). RF signals are suitable for shallow waters but experience significant signal attenuation in deep-sea environments. To enhance efficiency, onboard data processing optimises transmission, while relay stations extend the communication range. Future advancements in AI-driven data optimisation, hybrid communication networks, and satellite integration are expected to improve efficiency, autonomy, and global connectivity in subsea operations (Sulaiman et al., 2016; Intelligence, 2018; Sikdar et al., 2018; Stevens, Jolly, 2021; Wei et al., 2021; Saoud et al., 2024; Bello et al., 2024).

Environmental safety considerations

As illustrated, Wega (2013) and Choi (2023) stated that improvements in offshore mining using crawlers have focused on minimising ecological disruption while ensuring efficient resource extraction while MacDiarmid et al. (2014), Vogt (2022), Filho et al. (2021b), and Ummah (2019b) have discussed advanced sediment control systems for integrated tooling, which help reduce turbidity and prevent excessive dispersion of seabed materials, thereby protecting marine habitats. Low-impact track designs distribute crawler weight evenly, minimising substrate disturbance and preserving benthic ecosystems. Real-time monitoring sensors track water quality, noise levels, and ecosystem impact, enabling adaptive operations to mitigate environmental risks. Additionally, the use of biodegradable hydraulic fluids and energy-efficient electric systems helps reduce pollution and carbon footprint. Strict adherence to regulatory frameworks and sustainable mining practices ensures that offshore mining operations remain environmentally responsible while maximising resource recovery, stated by Glaviano et al. (2022) and Yaroshenko et al. (2020).

Autonomy and AI integration in crawler microcontrollers

Christensen et al. (2022), Chi et al. (2024), and Naga et al. (2023) have conducted similar research on autonomy and AI integration in remotely operated vehicle (ROV) microcontrollers, emphasising their role in enhancing real-time decision-making, navigation, and operational efficiency for offshore mining. AI-driven algorithms process sensor data to optimise movement, adjust dredging parameters, and detect obstacles, thereby reducing human intervention. Their research further highlights that microcontrollers integrate machine learning models to predict seabed conditions and adapt excavation strategies for improved efficiency. Autonomous path planning enables the crawler to navigate complex underwater terrain while avoiding environmental hazards and optimising resource extraction. Additionally, edge computing capabilities allow for rapid onboard data processing, minimising communication delays in deep-sea operations. This AI-powered system significantly improves operational reliability, energy efficiency, and precision in subsea mining and dredging applications (Li et al., 2019; Huang, Savkin, 2017; Abdullah et al., 2024; Xie et al., 2023; Khan et al., 2022).

A systematic review of hybrid quadrotor-track subsea robotic crawler for offshore mineral mining

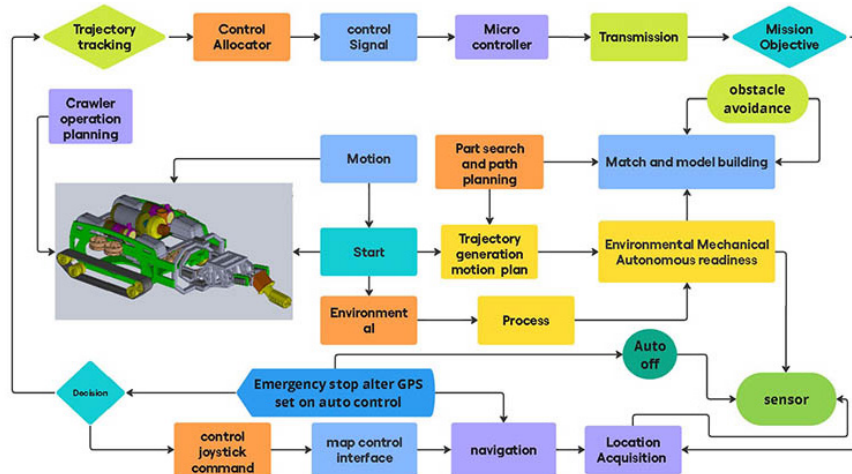

Figure 9—Autonomous crawler navigation structure

Energy efficiency and power management in mining crawlers

Mining crawlers optimise energy consumption to enhance operational longevity and reduce environmental impact, according to Ojumu (2022), Duraccio and Mussano (2015), Ukoba et al. (2024), Biswas et al. (2024), Li et al. (2023), Choi and Kim (2024), U.S. Department of Energy, (2019), and Thomas (2023). Furthermore, Geertsma et al. (2017), Stimmel (2016), Hirata et al. (2022), Jones et al. (2019), Muthugala et al. (2021), Geertsma et al. (2017), Piñeiro et al. (2004), Jones et al. (2019), and Hirata et al. (2022) described smart power distribution algorithms as a dynamic system, which allocate energy to critical control signals, ensuring efficient propulsion, dredging, and sensor operations. Regenerative power systems harness energy from braking and quadrotor rover movements, improving overall efficiency and reducing wastage. Advanced battery management and hybrid power sources integrate renewable energy options, such as fuel cells or subsea charging stations, to extend mission endurance. AI-driven monitoring systems continuously analyse power usage patterns, enabling real-time adjustments for optimal performance. This energy-efficiency approach enhancement for crawler sustainability, cost-effectiveness, and environmental compliance in deep-sea mining operations is mentioned by Mikołajczyk et al. (2023), Duraccio and Mussano, (2015), Bamisile et al., (2024), and (Bamisile et al., 2024).

The quadrotor crawler autonomous navigation structure, as seen in Figure 9, follows a systematic approach that integrates control, motion planning, and environmental perception to ensure efficient navigation, which appeared in similar research reported by Zheng et al. (2017), Alanezi et al. (2022), Kovryzhenko et al. (2024), and Saeedi et al. (2016). According to Gao and Shen (2016), Zheng et al. (2017), and Zhong et al. (2024), the control system for autonomous quadrotors are integrated in real-time re-planning capabilities, combining motion planning with environmental perception to enhance navigation efficiency. This process begins with trajectory tracking and control allocation, where the system manages movement through a control allocator. The microcontroller processes control signals and transmits them to execute the mission objectives. Motion planning and path search enable the crawler to navigate optimised routes while avoiding obstacles, further refined by model matching and obstacle avoidance mechanisms, which enhance environmental mapping and decision-making. Once motion planning is finalised, the system ensures environmental

readiness before initiating movement, ensuring smooth operation, as outlined by researchers such as, Pandey (2016; 2017), Bello and Baballe, (2023), and Anand et al. (2024).

According to Olusegun (2025) and Al-Jumaili and Özok (2024), navigation, trajectory generation, and process handling execute the planned motion while considering environmental factors, while real-time positional feedback from sensors, GPS, and location acquisition modules, enhance autonomous movement, as mentioned by Abdallaoui et al. (2023), as well as Zimmermann and Wotawa (2020). To maintain safety, the system incorporates emergency handling and auto-off mechanisms, which shift the GPS to auto-control mode in case of unforeseen conditions, as stated by Svensson (2018) and Abdallaoui et al. (2023). Additionally, Xu et al. (2021) stated that operators can override autonomy using joystick-based manual controls when necessary. The decision-making and adaptive control module continuously evaluates conditions, dynamically adjusting navigation for efficiency and safety in real-time operations (Katona et al., 2024; Safety D, 2020).

Conclusions

This paper highlighted the transformative role of the 4IR in advancing offshore mineral mining through the integration of electrically powered quadrotor-track subsea robotic crawlers. The rapid evolution of automation, artificial intelligence, sensor-based control mechanisms, and hybrid propulsion systems has significantly enhanced the efficiency, manoeuvrability, and adaptability of subsea crawlers in extreme underwater environments, as presented in the results.

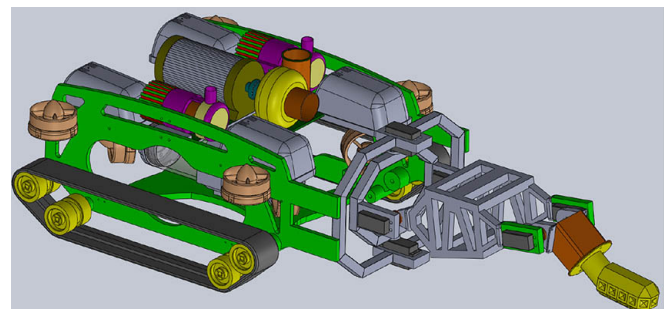

Figure 10—Design of an electrically powered quadrotor-track hybrid subsea robotic crawler

A systematic review of hybrid quadrotor-track subsea robotic crawler for offshore mineral mining

Table 4

Benefits, methods, and challenges in offshore mineral mining with electrically powered quadrotor-track subsea crawlers in Industry 4.0

Application Area	Methods Used	References	Main advantages	Main disadvantage
Path Planning, Obstacle avoidance, Adaptive mobility	A/D algorithm, D* Lite, reinforcement learning, Sensor fusion (IMU, LiDAR, depth cameras)	Maus et al. (2022); Igogo et al. (2021); Christensen et al. (2022); Oluokun et al. (2025); Toledano et al. (2012); Song and Zhang (2023); Luo et al. (2020); Almazrou et al. (2023); Tiwar et al. (2025), Leong and Ahmad, (2024); Min et al. (2024); Mai et al. (2024); Ball and Lieberman (2024); Zhu, et al. (2024); (Liu, et al. (2022); Chen et al. (2022); Kulathunga, (2022); Mendez et al. (2021).	Enhanced accessibility to mineral-rich areas using advanced software.	Energy efficiency and power supply limitations.
Marine environment assessment	Eco-conscious path planning. Environmental sensing, redundant communication. Real-time monitoring, restoration data analysis	Moloney (2006); Farran (2022); Liu et al. (2023); Leal Filho et al. (2021a); Sharma (2011); Sharma (2015); Van Dover et al. (2017); Metaxas et al. (2024); Verma (2024); Sumaila et al. (2023); Sharma (2015); Hercus (2023); Murdock (2023); Sun et al. (2024); NOAA Office of Ocean and Coastal Resource Management (2010); Donaldson (2018); Amazon.Inc (2020); Canada (2018); Ocean Trustee Implementation Group, (2019); Sun et al. (2024); Ummah (2019b).	Reduced environmental impact.	Harsh deep-sea conditions.
Control and navigation	MPC, RL-based control, PID, RRT/A planning, SLAM, Sensor fusion, Acoustic positioning, DTN, swarm routing, AI-based compression	Yoo et al. (2025); Kong et al. (2022); Meftah et al. (2024); Wang et al. (2020); Eskandari et al. (2021); Sharmilan and Abeysekara (2024); Yang et al. (2020); Xiao et al. (2022); Hadi et al. (2021); Christensen et al. (2022); Wang et al. (2022).	Improved manoeuvrability and precision	Navigation and communication constraints
Energy and fault management	RL energy management, Fault-tolerant control, Genetic algorithm, A search, Digital twins, Bayesian optimisation, Cloud-based AI	Shields and Young (1989); Marijan and Sen (2018); Meszle et al. (2020); Lutsey et al. (2017); Emmanuel (2024); Bauer (2017); Haraburda and Zilafro (2012); A. and C. (2011); Marijan and Sen (2018); Puppet Labs (2015); Mathur and Chaudhary (2024); Fang et al. (2025); Ma et al. (2024); Parvin et al. (2021); Zhao et al. (2022); Zhong et al. (2023); Recalde et al. (2024); Alhamrouni et al. (2024); Dahiya et al. (2024);Kowalski (2023).	Continuous operation and increased efficiency	High development and deployment costs
Data-driven decision making	AI/ML decision support, RL, Fuzzy logic, Big data (Hadoop, Spark), MCDA, Blockchain compliance, Emission modelling	Ministry et al. (1996); Raji et al. (2024); Olanrewaju et al. (2024); Cantor et al., (2021), Broms and Olsson (2021); Robinson et al. (2014); Chinnaraju (2025); Ikegwu et al. (2022); Paramesha et al. (2024).	Data-driven decision-making	Environmental and regulatory concerns
Condition monitoring and reliability	CBM, FDI, Self-healing, RL, Explainable AI, Fuzzy logic, Bayesian networks	Ucar et al. (2024); Raza (2024); Emma (2025); Prabu et al. (2025); Mohapatra (2024); Potter and Doris (2024); Vassileva et al. (2014); Jang et al. (2023), Mansouri et al. (2020); Wang et al. (2022); Baballe et al. (2022); Shin and Jun (2015); Teixeira et al. (2014); Zhu et al. (2023).	Lower maintenance costs and longer lifespan	Autonomy and AI reliability
Safety and integration	Hazard detection, RL safety mechanisms, Kalman and particle filters, Digital twin, IoT Edge processing, Blockchain integration	Wang and Guo (2023); Aber et al. (2021); Aziz et al. (2020); Molaei et al. (2020); Yaqot and Menezes (2023); Saganiak and Buketov (2024); Toledano et al. (2022); Dudley and McAree (2013); DIS (2016); Soderbaum (2020); Biernacki (2025); Menges et al. (2024); Biswas and Wang (2023); Zhukabayeva et al. (2025); Ucar et al. (2024); Yu and He (2022).	Safer mining operations	Integration with existing mining infrastructure
Predictive maintenance and control	MPC, RL, SLAM, Kalman filters, Predictive maintenance (AI/ML)	Becker et al. (1997); Ross et al. (2000); Arts et al. (2007); Lau and Song (2008); Report (2015); Ferrer et al. (2016); Lau and Song (2008); Wang and Ahmad (2024); Oladele (2025); Ernst et al. (2009); Sun et al. (2024).	Multi-modal deployment capabilities	Limited repair and maintenance options

A systematic review of hybrid quadrotor-track subsea robotic crawler for offshore mineral mining

Table 4 (continued)
Benefits, methods, and challenges in offshore mineral mining with electrically powered quadrotor-track subsea crawlers in Industry 4.0

Application Area	Methods Used	References	Main advantage	Main disadvantage
Swarm intelligence and ethics	Swarm intelligence, Plug-and-play Middleware (ROS), Explainable and ethical AI, Distributed computing	Thomson and Abadi (2013); Islam et al. (2023); Sun (2019); Sugiura et al. (2017); Rao (2021); Vision (2025b); Martínez et al. (2024); Engineering (2020); Soldatos and Kyriazis (2021); Schmidt and Ahlström (2024); Digest (2017).	Scalability and modularity	Public perception and ethical concerns
Industrial IoT and smart automation	IIoT, Edge AI, Digital twins, Predictive maintenance, Modular software integration, Cloud/Edge for Infrastructure	Özenir and İpek (2022); Al Mawali et al. (2021); Abdullah et al. (2022); Shadravan and Parsaei (2024); Sanghavi et al. (2019); Bakhtari et al. (2020); Broto Legowo and Indiarso (2021); et al. (2024), Asadollahi-Yazdi et al. (2020); Manufacturing (2024); Shanbhag et al. (2023); Abdul-Yekeen et al. (2024); Prozessindustrie (2025); Dervişoğlu et al. (2023); Shanbhag et al. (2023).	Alignment with Industry 4.0	High initial investment costs

The integration of real-time AI-driven control mechanisms, and hybrid communication networks (fibre optics, acoustic, RF, and satellite integration) has enabled unprecedented advancements in deep-sea exploration and mining. The incorporation of quadrotor-assisted mobility into traditional track-based crawlers has addressed key challenges related to hydrodynamic stability, seabed navigation, and excavation efficiency, as illustrated in Figure 10. These improvements not only optimise the performance of robotic mining crawlers but also ensure minimal environmental impact through precise excavation, real-time monitoring, and reduced turbidity.

A key finding of this study is the introduction of hydraulic crawlers, using its advancement in electrically powered systems, significantly for enhancing its energy efficiency, reducing operational costs, and improving long-term sustainability. The adoption of variable frequency drives (VFD), advanced telemetry systems (GPS RTK-based navigation), and AI-powered decision-making algorithms has further strengthened the autonomous capabilities of subsea crawlers, enabling real-time adaptation to complex underwater terrains.

Despite these advancements, challenges remain in power management, endurance, and real-time data transmission across large operational depths. Future research should focus on wireless energy transfer technologies, AI-optimised mission planning, and AI-powered underwater robotic swarms for collaborative deep-sea mining. Additionally, the implementation of blockchain-based autonomous operations could improve transparency, resource tracking, and efficiency in offshore mining as designed and introduced in Figure 10.

In conclusion, the findings of this systematic review established that electrically powered quadrotor-track subsea robotic crawlers represent a breakthrough in deep-sea mining technology. By leveraging AI, automation, and sustainable power solutions, these systems can drive the next generation of autonomous subsea excavation, environmental monitoring, and global offshore resource extraction, paving the way for a more efficient and sustainable approach to deep-sea dredging operations.

Acknowledgments

This study was funded by the Cape Peninsula University of Technology (CPUT), Cape Town, South Africa.

Conflict of interest

The authors declare no conflict of interest.

References

- Abdallaoui, S., Ikaouassen, H., Kribèche, A., Chaibet, A., Aglzim, E.H. 2023. 'Advancing autonomous vehicle control systems: An in-depth overview of decision-making and manoeuvre execution state of the art'. *The Journal of Engineering*, vol. 11, pp. 1–16. Available at: <https://doi.org/10.1049/tje2.12333>
- Abdul, Y., Abideen, M.R., Opeyemi, A., Maryam, A.S., Azeezat, K., Victoria, A., Tawakalit, O. 2024. 'Utilizing the Internet of Things (IoT), Artificial Intelligence, Machine Learning, and Vehicle Telematics for Sustainable Growth in Small and Medium Firms (SMEs)'. *Journal of Artificial Intelligence General Science*, vol. 5, no. 1, pp. 237–374. Available at: <https://doi.org/10.60087/jaigs.v5i1.197>
- Abdullah, A., Chen, R., Blow, D., Uthai, T., Du, E. J., Islam, M.J. 2024. 'Human-Machine Interfaces for Subsea Telerobotics: From Soda-straw to Natural Language Interactions', pp. 1–37. Available at: <http://arxiv.org/abs/2412.01753>
- Abdullah, F.M., Saleh, M., Al-Ahmari, A.M., Anwar, S. 2022. 'The Impact of Industry 4.0 Technologies on Manufacturing Strategies: Proposition of Technology-Integrated Selection'. *IEEE Access*, vol. 10, pp. 21574–21583. Available at: <https://doi.org/10.1109/ACCESS.2022.3151898>
- Aizelman, I., Magazinnik, D., Feldman, D., Klein, I. 2024. 'Quadrotor with wheels: design and experimental evaluation'. *Scientific Reports*, vol. 14, no. 1, pp. 1–13. Available at: <https://www.nature.com/articles/s41598-024-66396-0>
- Ajay, A., Devika, S., Megha, A.J., Praseetha, S., Shyba, Z. 2024. 'Implementation of Online Path Planning and Obstacle Avoidance Using Yolo for Autonomous Mobile Robots'. *Journal of Mechanics Engineering and Automation*, vol. 6, no. 4. Available at: <https://doi.org/10.17265/2159-5275/2016.04.005>
- Alanezi, M.A., Haruna, Z., Sha'aban, Y.A., Boucekara, H.R.E.H., Nahas, M., Shahriar, M.S. 2022. 'Obstacle Avoidance-Based Autonomous Navigation of a Quadrotor System'. *Drones*, vol. 6, no. 10, pp. 1–19. Available at: <https://doi.org/10.3390/drones6100288>

A systematic review of hybrid quadrotor-track subsea robotic crawler for offshore mineral mining

- Alanhdhi, A., Toka, L. 2024. 'A Survey on Integrating Edge Computing With AI and Blockchain in Maritime Domain, Aerial Systems, IoT, and Industry 4.0'. *IEEE Access*, pp. 28684–28709. Available at: <https://doi.org/10.1109/ACCESS.2024.3367118>
- Alhamrouni, I., Abdul Kahar, N.H., Salem, M., Swadi, M., Zahroui, Y., Kadhim, D.J., Mohamed, F.A., Alhuyi, N.M. 2024. 'A Comprehensive Review on the Role of Artificial Intelligence in Power System Stability, Control, and Protection: Insights and Future Directions'. *Applied Sciences* vol. 14, no. 14. Available at: <https://doi.org/10.3390/app14146214>
- Al-Jumaili, M.H., Özok, Y.E. 2024. 'New control model for autonomous vehicles using integration of Model Predictive and Stanley based controllers'. *Scientific Reports*, vol. 14, no. 1, pp. 1–15. Available at: <https://doi.org/10.1038/s41598-024-69858-7>
- Almazrouei, K., Kamel, I., Rabie, T. 2023. 'Dynamic Obstacle Avoidance and Path Planning through Reinforcement Learning'. *Applied Sciences*, vol. 13, no. 14. Available at: <https://doi.org/10.3390/app13148174>
- Amazon.Inc 2020. 'Amazon Sustainability Report', Amazon [Preprint]. Available at: <https://sustainability.aboutamazon.com/2020-sustainability-report.pdf>
- Amon, D.J., Levin, L.A., Metaxas, A., Mudd, G.M. Smith, C. 2025. 'Heading to the deep end without knowing how to swim: Do we need deep-seabed mining?', (November 2023), pp. 1–9. Available at: <https://doi.org/10.1016/j.oneear.2022.02.013>
- Donaldson, L. 2018. 'Florida Adaptation Planning Guidebook', p. 185. Available at: <https://floridadep.gov/sites/default/files/AdaptationPlanningGuidebook.pdf>
- Anand, A.S., Devika, A.J., Megha, P., Zaheer, S. 2024 'Implementation of Online Path Planning and Obstacle Avoidance Using Yolo for Autonomous Mobile Robots Implementation of Online Path planning and Obstacle Avoidance Using Yolo for Autonomous'. Available at: <https://doi.org/10.20944/preprints202406.1382.v1>
- Andreu-Perez, J. 2017. 'Artificial Intelligence and Robotics Javier Andreu Perez , Fani Deligianni , Daniele Ravi and Guang-Zhong Yang'. *ResearchGate* [Preprint], (June). Available at: <https://doi.org/10.48550/arXiv.1803.10813>
- Aranda, J., Armada, M.A., de la Cruz, J.M. 2004. Automation for the Maritime Industries Automation for the Maritime Industries. Available at: https://www.researchgate.net/profile/Joaquin-Almansa/publication/263580947_Automation_for_the_Maritime_Industries/links/00b7d53b476087cc3b000000/Automation-for-the-Maritime-Industries.pdf
- Arcangeletti, G., Mattioli, M., Ausborn, M., Matskevitch, D., Marcotulli, A. 2021 'Autonomous Subsea Field Development - Value Proposition, Technology Needs and Gaps for Future Advancement', pp. 1–1. Available at: <https://doi.org/10.4043/31151-MS>
- Arts, T., Policy, C., Justice, C., Security, N., Safety, P., Security, H. 2007. Jump down to document 6 The RAND Corporation is a nonprofit research organization providing Support RAND Purchase this document Make a charitable contribution For More Information Visit RAND at www.rand.org, Early Education.
- Asadollahi-Yazdi, E., Couzon, P., Nguyen, N., Ouazene, Y., Yalaoui, F. 2020. 'Industry 4.0: Revolution or Evolution?'. *American Journal of Operations Research*, vol. 10, no. 6, pp. 241–268. Available at: <https://doi.org/10.4236/ajor.2020.106014>
- Authority, I.S. 2006 'Polymetallic Nodules', International seabed authority, pp. 1–8. Available at: <http://www.isa.org.jm/files/documents/EN/Brochures/ENG7.pdf>
- Aziz, A., Schelén, O., Bodin, U. 2020. 'A Study on Industrial IoT for the Mining Industry: Synthesized Architecture and Open Research Directions'. *Internet of Things*, vol. 1, no. 2, pp. 529–550. Available at: <https://doi.org/10.3390/iot1020029>
- Baballe, M., Bello, M., Rabiou, S., Atiku, S. 2022. '1st International Conference on Engineering and Applied Natural Sciences', p. 2022. Available at: <file:///C:/Users/mikeo/Downloads/Baballe%20et%20al.%20-%202022%20-%201st%20International%20Conference%20on%20Engineering%20and%20Applied%20Natural%20Sciences.pdf>
- Bakhtari, A., Kumar, V., Waris, M., Sanin, C., Szczerbicki, E. 2020. 'Industry 4.0 implementation challenges in manufacturing industries: An interpretive structural modelling approach'. *Procedia Computer Science*, vol. 176, pp. 2384–2393. Available at: <https://doi.org/10.1016/j.procs.2020.09.306>
- Ball, L., Lieberman, L.J. 2024. 'Blind and Visually Impaired Sport'. *Blind and Visually Impaired Sport* [Preprint]. Available at: <https://doi.org/10.4324/9780367766924-ress115-1>
- Bamisile, O., Cai Dadun, H., Dagbasi, M., Ukwuoma, C., Huang, Q., Johnson, N., Bamisile, O. 2024. 'Towards Renewables Development: Review of Optimization Techniques for Energy Storage and Hybrid Renewable Energy Systems'. *Heliyon*, p. e37482. Available at: <https://doi.org/10.1016/j.heliyon.2024.e37482>
- Bauer, E. 2017 'Economic Efficiency of Cloud-Based Application E conomic E fficiency of Cloud- Based Application Services Working Draft'. Available at: <https://doi.org/10.13140/RG.2.2.22188.56969>
- Bauer, E. 2024. 'AI-driven predictive maintenance and optimization of renewable energy systems for enhanced operational efficiency and longevity'. Available at: https://www.researchgate.net/publication/385382721_AI-driven_predictive_maintenance_and_optimization_of_renewable_energy_systems_for_enhanced_operational_efficiency_and_longevity
- Becker, M., Smith, S.F. 1997. 'An Ontology for Multi-Modal Transportation Planning and Scheduling for Multi-Modal Transportation Planning and Scheduling Marcel Becker, Stephen F. Smith CMU-RI-TR-98-15. *The Robotics Institute* ?. Available at: https://www.researchgate.net/profile/Marcel-Becker-6/publication/2417156_An_Ontology_for_Multi-Modal_Transportation_Planning_and_Scheduling/links/540f31fb0cf2df04e75a2878/An-Ontology-for-Multi-Modal-Transportation-Planning-and-Scheduling.pdf
- Bello, M.I., Baballe, M.A. 2023. 'Simulation of Obstacle Avoidance Robots'. *Journal of Material Sciences and Engineering Technology*, vol. 1, no. 2, pp. 1–7. Available at: <https://doi.org/10.61440/jmset.2023.v1.16>
- Bessa, W. 2012. 'Analysis of four-wire lines umbilicals on subsea applications for the oil and gas industry. Analysis of Four-Wire Lines Umbilicals On Subsea'. Available at: https://www.researchgate.net/publication/282856648_Analysis_of_four-wire_lines_umbilicals_on_subsea_applications_for_the_oil_and_gas_industry

A systematic review of hybrid quadrotor-track subsea robotic crawler for offshore mineral mining

- Bian, J., Xiang, J. 2018. 'QUUV: A quadrotor-like unmanned underwater vehicle with thrusts configured as X shape'. *Applied Ocean Research*, vol. 78, pp. 201–211. Available at: <https://doi.org/10.1016/j.apor.2018.06.017>
- Biernacki, P. 2025. 'Artificial Intelligence for Electronic-based Systems in Safety Applications'. Available at: <https://doi.org/10.13140/RG.2.2.16865.42086>
- Biswas, A., Wang, H.C. 2023. 'Autonomous Vehicles Enabled by the Integration of IoT, Edge Intelligence, 5G, and Blockchain'. *Sensors*, vol. 23, no. 4, pp. 1–60. Available at: <https://doi.org/10.3390/s23041963>
- Biswas, P., Rashid, A., Biswas, A., Nasim, M., Chakraborty, S., Gupta, K., George, R. 2024. 'AI-Driven Approaches for Optimizing Power Consumption: A Comprehensive Survey', pp. 1–32. Available at: <http://arxiv.org/abs/2406.15732>
- Bohacz, R., and Successful Farming. 2019. Know the Difference Between Mechanical and Hydraulic Valve Lifters | Successful Farming. (Accessed: 12 September 2021). Available at: <https://www.agriculture.com/machinery/repair-maintenance/know-the-difference-between-mechanical-and-hydraulic-valve-lifters>
- Bosch, R.A.G. 2014. 'Drive and control solutions for marine engineering: Reliable, efficient, durable', p. 24. Available at: file:///C:/Users/mikeo/Downloads/r999001175_2015-1.pdf
- Bouabdallah, S., Siegwart, R. 2007. 'Full control of a quadrotor'. IEEE International Conference on Intelligent Robots and Systems, (October 2007), pp. 153–158. Available at: <https://doi.org/10.1109/IROS.2007.4399042>
- Bourechak, A., Zedadra, O., Kouahla, M., Guerrieri, A., Seridi, H., Fortino, G. 2023. 'At the Confluence of Artificial Intelligence and Edge Computing in IoT-Based Applications: A Review and New Perspectives'. *Sensors*, vol. 23, no. 3, pp. 1–49. Available at: <https://doi.org/10.3390/s23031639>
- Broms, A., Olsson, S.L. 2021. 'Data-driven Decision-making for Efficient & Sustainable Production'. Available at: <https://www.diva-portal.org/smash/record.jsf?pid=diva2%3A1567809&dsid=7419>
- Broto, L.M., Indianto, B. 2021. 'Issues and Challenges in Implementing Industry 4.0 for the Manufacturing Sector in Indonesia'. *International Journal of Progressive Sciences and Technologies*, vol. 25, no. 1, p. 650. Available at: file:///C:/Users/mikeo/Downloads/Issues_and_Challenges_in_Implementing_Industry_40_.pdf
- Building, T.N., Honcho, N. 2024. 'Maritime RTK-GNSS Positioning System', pp. 13–16. Available at: https://www.mar-gps.or.jp/guide/file/pamphlet_e.pdf
- Canada, I.A.A. of 2018. 'Final Environmental Assessment Guidelines'. Available at: <https://pressbooks.openeducationalberta.ca/mruenvregs/chapter/impact-assessment-acts/>
- Cantor, A., Kiparsky, M., Hubbard, S., Kennedy, R., Pecharroman, L., Guivetchi, K., Darling, G., McCready, C. 2021. 'Making a Water Data System Responsive to Information Needs of Decision Makers'. *Frontiers in Climate*, vol. 3. Available at: <https://doi.org/10.3389/fclim.2021.761444>
- Chandni, S. 2024. 'Digital Oversight : The Rise of Ai in Transforming Employee'. Available at: <file:///C:/Users/mikeo/Downloads/4Chandni.doc.pdf>
- Chen, G., Chen, W., Wang, Z., Guo, T., Xia, X., Xu, L. 2022. 'Design and Dynamic Performance Research of Underwater Inspection Robots' *Wireless Communications and Mobile Computing*. Available at: <https://doi.org/10.1155/2022/3715514>
- Chen, L., Jiang, Z., Cheng, L., Knoll, A., Zhou, M. 2022. 'Deep Reinforcement Learning Based Trajectory Planning Under Uncertain Constraints'. *Frontiers in Neurorobotics*, vol. 16, pp. 1–10. Available at: <https://doi.org/10.3389/fnbot.2022.883562>
- Chen, P., Liu, Y., Yang, S., Chen, J., Zhang, Q., Tang, Y. 2021. 'Dynamic characteristics of deep-sea ROV umbilical cables under complex sea conditions'. *Ocean Engineering*, vol. 239, p. 109854. Available at: <https://doi.org/10.1016/j.oceaneng.2021.109854>
- Chi, P., Wang, Z., Liao, H., Li, T., Wu, X., Zhang, Q. 2024. 'Application of artificial intelligence in the new generation of underwater humanoid welding robots: a review'. *Artificial Intelligence Review*, vol. 57, no. 11. Available at: <https://doi.org/10.1007/s10462-024-10940-x>
- Chinnaraju, A. 2025. 'AI-driven strategic decision-making on innovation: Scalable, ethical approaches and ai agents for startups'. *World Journal of Advanced Research and Reviews*, vol. 25, no. 2, pp. 2219–2248. Available at: <https://doi.org/10.30574/wjarr.2025.25.2.0575>
- Choi, E., Kim, H. 2024. 'Advanced Energy Management System for Generator-Battery Hybrid Power System in Ships: A Novel Approach with Optimal Control Algorithms'. *Journal of Marine Science and Engineering*, vol. 12, no. 10. Available at: <https://doi.org/10.3390/jmse12101755>
- Choi, E.C. 2023. 'Investigating the management of marine sand mining: A case of West Sea Exclusive Economic Zone in South Korea'. *Regional Studies in Marine Science*, vol. 66, p. 103109. Available at: <https://doi.org/10.1016/j.rsma.2023.103109>
- Christensen, L., de Gea Fernández, J., Hildebrandt, M., Koch CWehbe, B. 2022. 'Recent Advances in AI for Navigation and Control of Underwater Robots'. *Current Robotics Reports*, vol. 3, no. 4, pp. 165–175. Available at: <https://doi.org/10.1007/s43154-022-00088-3>
- Cohan, S. 2008. 'Trends in ROV development'. *Marine Technology Society Journal*, vol. 42, no. 1, pp. 38–43. Available at: <https://doi.org/10.4031/002533208786861335>
- Cole, E. 2012. 'Mining the Seafloor with Robots'. *Robotics Trends*, pp. 1–4. Available at: https://www.iaarc.org/wp-content/uploads/2020/01/a_news_2012_09_11-1.pdf
- Corke, P., Roberts, J., Cunningham, J., Hainsworth, D. 2008. 'Springer Handbook of Robotics'. *Springer Handbook of Robotics* [Preprint], (May 2014). Available at: <https://doi.org/10.1007/978-3-540-30301-5>
- Costa, G.K., Sepehri, N. 2020. 'A critical analysis of flow-compensated hydrostatic single rod actuators: Simulation study'. *Actuators*, vol. 9, no. 3. Available at: <https://doi.org/10.3390/ACT9030058>
- Cudney, E.A., Eldor, C.C. 2011. 'Quality Function Deployment in Continuous Improvement', Six Sigma Projects and Personal Experiences [Preprint], (June). Available at: <https://doi.org/10.5772/16602>
- Dahiya, V., Swathi, P., Baskar, K., Akbar, M. 2024. 'Integrating digital twin technology and artificial intelligence for tomorrow's

A systematic review of hybrid quadrotor-track subsea robotic crawler for offshore mineral mining

- businesses: Strategic imperatives'. *Digital Twin Technology and AI Implementations in Future-Focused Businesses*, pp. 162–175. Available at: <https://doi.org/10.4018/979-8-3693-1818-8.ch011>
- 'Debmarmine Namibia's offshore' 2017. Available at: <https://www.debeersgroup.com/~media/Files/D/De-Beers-Group/documents/company-news/2017/media-release-worlds-most-advanced-diamond-exploration-vessel-officially-reports-for-duty-in-namibia.pdf>
- Delphin Raj, K.M., Sun-Ho, Y., Ko, E., Namgung, S., Park, S. 2019. 'Multi-media and multi-band based adaptation layer techniques for underwater sensor networks', *Applied Sciences* (Switzerland), 9(15). Available at: <https://doi.org/10.3390/app9153187>
- Dervişoğlu, H., Ülver, B., Yurtoğlu, R., Halepmollası, R., Haklıdır, M. 2023. 'A Comparative Study on Cloud-based and Edge-Based Digital Twin Frameworks for Prediction of Cardiovascular Disease'. *International Conference on Information and Communication Technologies for Ageing Well and e-Health, ICT4AWE - Proceedings*, pp. 159–169. Available at: <https://doi.org/10.5220/0011859400003476>
- Digest, A.A.I. 2017. 'Applied AI Digest', vol. 1. Available at: <https://bootstraplabs.com/2018/01/24/applied-artificial-intelligence-digest-2017-review/>
- DIS 2016. 'Mine Rehabilitation: Leading Practice Sustainable Development Program for the Mining Industry', pp. 1–76. Available at: <file:///C:/Users/mikeo/Downloads/London%20Convention%20et%20al.%20-%202013%20-%20International%20Assessment%20of%20Marine%20and%20Riverine%20Disposal%20of%20Mine%20Tailings%20Study%20commissioned%20by%20the%20Of.pdf>
- Dudley, J.J., McAree, P.R. 2013. 'Why the mining industry needs a reference architecture for automation initiatives'. *IEEE/ASME International Conference on Advanced Intelligent Mechatronics: Mechatronics for Human Wellbeing, AIM 2013*, pp. 1792–1797. Available at: <https://doi.org/10.1109/AIM.2013.6584357>
- Duraccio, D., Mussano, F. 2015. 'And Future Trends'. *Journal of Materials Science*, vol. 50, no. 14, pp. 4779–4812. Available at: <file:///C:/Users/mikeo/Downloads/Biomaterialsfordentalimplantscurrentandfuturetrends.pdf> (Dental website?) Efficiency, dragflow ultimate. 2023. *Dredging Pumps*. Available at: <file:///C:/Users/mikeo/Downloads/Biomaterialsfordentalimplantscurrentandfuturetrends.pdf>
- Efficiency, dragflow ultimate. 2023. 'Dredging Pumps'. Available at: https://ccelp.com/wp-content/uploads/2023/06/Dragelectricpumps_english.pdf
- Elkholy, M., Senjyu, T., Lotfy, M., Elgarhy, A., Ali, N., Gaafar, T. 2022. 'Design and Implementation of a Real-Time Smart Home Management System Considering Energy Saving'. Available at: <https://www.mdpi.com/2071-1050/14/21/13840>
- Elsaed, E., Linjama, M. 2023. 'A Review of Pilot-operated Hydraulic Valves - Development, Challenges, and a Comparative Study'. *International Journal of Fluid Power*, vol. 24, no. 4), pp. 683–724. Available at: <https://doi.org/10.13052/ijfp1439-9776.2443>
- Emma, L. 2025. 'AI-Driven Predictive Maintenance for Smart Manufacturing'. Available at: <file:///C:/Users/mikeo/Downloads/AI.pdf>
- Emmanuel. 2024. 'The Future of CI / CD : Leveraging AI for Seamless Deployments'. Available at: <file:///C:/Users/mikeo/Downloads/TheFutureofCICDLeveragingAIforSeamlessDeployments.pdf>
- Engineering, A.I. 2020. 'Annual Report. Progressing towards Robust and Trustworthy AI Systems'. Available at: <https://www.nitr.gov/pubs/AI-Research-and-Development-Progress-Report-2020-2024.pdf>
- Engineering, I. 2022. 'Undercarriage Solutions and Components Engineered for Success'. Available at: <https://www.group-itm.com/en/>
- Enterprise, S. 2018. 'Seabed Mining, Mineral Extraction & Methane Hydrates', (April). Available at: <https://www.scottish-enterprise.com/media/e01pftb4/subsea-engineering-opportunity-international-market-insights-report-series-seabed-mining-mineral-ext.pdf>
- Ernst, D., Glavic, M., Capitanescu, F., Wehenkel, L. 2009. 'Reinforcement learning versus model predictive control: A comparison on a power system problem'. *IEEE Transactions on Systems, Man, and Cybernetics, Part B: Cybernetics*, vol. 39, no. 2, pp. 517–529. Available at: <https://doi.org/10.1109/TSMCB.2008.2007630>
- Eskandari, M. 2021. 'Navigation of a UAV Equipped with a Reconfigurable Intelligent Surface for LoS Wireless Communication with a Ground Vehicle', pp. 1–10. Available at: <http://arxiv.org/abs/2110.09012>
- Excav8. 2024. '6" ROV Dredge Pump', 001, p. 202. Available at: https://www.excav8subsea.com/uploads/DREDGE-001-Data-Sheet-Rev3_2024-10-16-065454_fruj.pdf
- Eyitayo, R., Tochukwu, I. I., Osemeike, G. E. 2024. 'Data-Driven decision making in agriculture and business: The role of advanced analytics'. *Computer Science & IT Research Journal*, vol. 5, no. 7, pp. 1565–1575. Available at: <https://doi.org/10.51594/csitjr.v5i7.1275>
- Fang, Y., Zhang, Y., Li, N., Shang, Y. 2020. 'Research on a medium-tracked omni-vehicle', pp. 137–152. Available at: <https://ms.copernicus.org/articles/11/137/2020/>
- Fang, Z.M.T., Huang, J., Niu, Z., Yang, F. 2025. 'Efficient Task Allocation in Multi-Agent Systems Using Reinforcement Learning and Genetic Algorithm'. *Applied Sciences*, vol. 15, no. 4. Available at: <https://doi.org/10.3390/app15041905>
- Fard, R.N., Eidsvik, O.A., Tedeschi, E., Scholberg, I. 2018. 'Cable selection considerations for subsea vehicles', 2018 OCEANS - MTS/IEEE Kobe Techno-Oceans, OCEANS - Kobe 2018 [Preprint]. Available at: <https://doi.org/10.1109/OCEANSKOB.2018.8559225>
- Farran, S. 2022. 'Deep-sea mining and the potential environmental cost of "going green" in the Pacific'. *Environmental Law Review*, vol. 24, no. 3, pp. 173–190. Available at: <https://doi.org/10.1177/14614529221114947>
- Ferrer, A.J., Pérez, D.G., González, R.S. 2016. 'Multi-cloud Platform-as-a-service Model, Functionalities and Approaches', *Procedia Computer Science*, 97, pp. 63–72. Available at: <https://doi.org/10.1016/j.procs.2016.08.281>
- Fleming, M., Brannen, S., Mosher, A., Altmire, B., Metrick, A., Boyle, M., Say, R. 2015. 'Unmanned Systems in Homeland Security'. *Homeland Security Studies and Analysis Institute* [Preprint], (January). Available at: https://csis-website-prod.s3.amazonaws.com/s3fs-public/legacy_files/files/attachments/151216_Unmanned_Systems.pdf

A systematic review of hybrid quadrotor-track subsea robotic crawler for offshore mineral mining

- Gaber, T., Jazouli, Y.E., Eldesouky, E., Ali, A. 2021. 'Autonomous haulage systems in the mining industry: Cybersecurity, communication and safety issues and challenges'. *Electronics*, vol. 10, no. 11. Available at: <https://doi.org/10.3390/electronics10111357>
- Gao, F., Shen, S. 2016. 'Online quadrotor trajectory generation and autonomous navigation on point clouds'. *SSRR 2016 - International Symposium on Safety, Security and Rescue Robotics*, pp. 139–146. Available at: <https://doi.org/10.1109/SSRR.2016.7784290>
- Gedigital 2019. Automation as the Edge Node of the Industrial Internet. Available at: <https://www.novotek.com/wp-content/uploads/sites/9/NovotekBenelux/SOLUTIONHMISCADA/Automation-as-the-Edge-Node-of-the-Industrial-Internet-1.pdf>
- Geertsma, R.D. 2017. 'Design and control of hybrid power and propulsion systems for smart ships: A review of developments'. *Applied Energy*, vol. 194, pp. 30–54. Available at: <https://doi.org/10.1016/j.apenergy.2017.02.060>
- George, A.S. 2024 'The Fourth Industrial Revolution: A Primer on Industry 4.0 and its Transformative Impact'. Available at: https://www.researchgate.net/publication/378261588_The_Fourth_Industrial_Revolution_A_Primer_on_Industry_4_0_and_its_Transformative_Impact
- Glaviano, F., Esposito, R., Di Cosmo, A., Esposito, F., Gerevini, L., Ria, A., Molinara, M., Bruschi, P., Costantini, M., Zupo, V. 2021. 'IoT Based Underwater Robot for Water Quality Monitoring'. *IOP Conference Series: Materials Science and Engineering*, vol. 1033, no. 1). Available at: <https://doi.org/10.1088/1757-899X/1033/1/012013>
- Glaviano, F., Esposito, R., Di Cosmo, A., Esposito, F., Gerevini, L., Ria, A., Molinara, M., Bruschi, P., Costantini, M., Zupo, V. 2022. 'Management and Sustainable Exploitation of Marine Environments through Smart Monitoring and Automation'. *Journal of Marine Science and Engineering*, vol. 10, no. 2. Available at: <https://doi.org/10.3390/jmse10020297>
- Hadi, B., Khosravi, A., Sarhadi, P. 2021. 'A Review of the Path Planning and Formation Control for Multiple Autonomous Underwater Vehicles'. *Journal of Intelligent and Robotic Systems: Theory and Applications*, vol. 101, no. 4. Available at: <https://doi.org/10.1007/s10846-021-01330-4>
- Haga, M., Hiroshi, W., Fujishima, K. 2001. 'Digging control system for hydraulic excavator'. *Mechatronics*, vol. 11, no. 6, pp. 665–676. Available at: [https://doi.org/10.1016/S0957-4158\(00\)00043-X](https://doi.org/10.1016/S0957-4158(00)00043-X)
- Haraburda, S.S., Zilafro, L.E. 2012. 'Developing a Continuous Improvement System', Defense AT&L, pp. 29–32. Available at: https://www.dau.edu/sites/default/files/Migrate/DATLFiles/Jan_Feb_2012/Haraburda_Zilafro.pdf
- Hein, H.A. 2015. 'Deep sea mining – what makes it different to offshore oil and gas applications?', (July 2014). Available at: [file:///C:/Users/mikeo/Downloads/HTIKE%20Aung%20Hein%20-%20Full%20Thesis%204th%20Cohort,%20Feb%202015%20%20\(URO\).pdf](file:///C:/Users/mikeo/Downloads/HTIKE%20Aung%20Hein%20-%20Full%20Thesis%204th%20Cohort,%20Feb%202015%20%20(URO).pdf)
- Hercus, C. 2023. 'Deep Sea Mining', *Canadian Mining Journal*, vol. 144, no. 9, pp. 28–30. Available at: <https://doi.org/10.1093/oso/9780198841654.003.0005>
- Hirata, E., Watanabe, D., Lambrou, M. 2022. 'Shipping Digitalization and Automation for the Smart Port', Supply Chain - Recent Advances and New Perspectives in the Industry 4.0 Era [Preprint], (January). Available at: <https://doi.org/10.5772/intechopen.102015>
- Hong, S., Hu, X. 2022. 'Study on the Non-Steady-State Wear Characteristics and Test of the Flow Passage Components of Deep-Sea Mining Pumps'. *Applied Sciences*, vol. 12, no. 2. Available at: <https://doi.org/10.3390/app12020782>
- Hu, Q., Zhai, X., Li, Z. 2022. 'Multi-Objective Optimization of Deep-Sea Mining Pump Based on CFD, GABP Neural Network and NSGA-III Algorithm'. *Journal of Marine Science and Engineering*, vol. 10, no. 8. Available at: <https://doi.org/10.3390/jmse10081063>
- Hu, W., Meng, Z. 2020 'Study on Design of Working Device and Hydraulic System of Hydraulic Excavator Based on Computer Aided Technology'. *Journal of Physics: Conference Series*, vol. 1574, pp. 1–7. Available at: <https://doi.org/10.1088/1742-6596/1574/1/012028>
- Humphreys, D. 2020. 'Mining productivity and the fourth industrial revolution'. *Mineral Economics*, vol. 33, nos.1–2, pp. 115–125. Available at: <https://doi.org/10.1007/s13563-019-00172-9>
- Humphreys, D. 2020. 'Mining productivity and the fourth industrial revolution', pp. 115–125. Available at: https://www.researchgate.net/publication/331191148_Mining_productivity_and_the_fourth_industrial_revolution
- Hung, H., Savkin, A.V. 2017. 'Viable path planning for data collection robots in a sensing field with obstacles'. *Computer Communications*, vol. 111, pp. 84–96. Available at: <https://doi.org/10.1016/j.comcom.2017.07.010>
- Hunter, R. J. 2007. 'Investigation of the application of mechanical mining of ocean floor polymetallic sulphide deposits', pp. 1–154. Available at: <https://doi.org/10.14288/1.0067064>
- Idrissi, M., Annaz, F. 2020. 'Dynamic modelling and analysis of a quadrotor based on selected physical parameters'. *International Journal of Mechanical Engineering and Robotics Research*, vol. 9, no. 6, pp. 784–790. Available at: <https://doi.org/10.18178/ijmerr.9.6.784-790>
- Igogo, T., Awuah-Offei, K., Newman, A., Lowder, T., Engel-Cox, J. 2021. 'Integrating renewable energy into mining operations: Opportunities, challenges, and enabling approaches'. *Applied Energy*. Available at: <https://doi.org/10.1016/j.apenergy.2021.117375>
- Ikegwu, A.C., Nweke, H.F., Anikwe, C.V., Alo, U.R., Okonkwo, O. R. 2022. 'Big data analytics for data-driven industry: a review of data sources, tools, challenges, solutions, and research directions'. *Cluster Computing*, vol. 25, no. 5, pp. 3343–3387. Available at: <https://doi.org/10.1007/s10586-022-03568-5>
- IMDH Group 2016. Team | IMDH Group International Mining & Dredging Holding Ltd. Accessed: 28 July 2021. Available at: <https://www.imdhgroup.com/team.php>
- Intelligence, A. 2018. 'The impact of Artificial Intelligence on communication networks', vol. 1, no. 1. Available at: <https://www.itu.int/pub/S-JOURNAL-ICTF.VOL1-2018-1>
- International seabed authority (ISA) 2021. Technical Study 30: Marine mineral resources: scientific and technological advances. Available at: https://www.isa.org.jm/wp-content/uploads/2022/05/ISA_Technical_Study-30.pdf
- Islam, M., Maxwell, D., Bunster, V., Couper, R. 2023. 'Modularity as an enabler of scalability in industrialised building platforms'. Available at: <https://doi.org/10.60558/ea16-2023-230>

A systematic review of hybrid quadrotor-track subsea robotic crawler for offshore mineral mining

- Jacewicz, M., Żugaj, M., Głębocki, R., Bibik, P. 2022. 'Quadrotor Model for Energy Consumption Analysis'. *Energies*, vol. 15, no. 19. Available at: <https://doi.org/10.3390/en15197136>
- Jain, A., Rodriguez, G. 1992. 'Recursive flexible multibody system dynamics using spatial operators'. *Journal of Guidance, Control, and Dynamics*, vol. 15, no. 6, pp. 1453–1466. Available at: <https://doi.org/10.2514/3.11409>
- Jang, K., Pilario, K.E.S., Lee, N., Moon, I.I., Jonggeol, N. 2023. 'Explainable Artificial Intelligence for Fault Diagnosis of Industrial Processes'. *IEEE Transactions on Industrial Informatics* [Preprint], (January). Available at: <https://doi.org/10.1109/TII.2023.3240601>
- Jensen, K.J., Ebbesen, M.K., Hansen, M.R. 2020. 'Development of point-to-point path control in actuator space for hydraulic knuckle boom crane'. *Actuators*, vol. 9, no. 2, pp. 1–19. Available at: <https://doi.org/10.3390/ACT9020027>
- Johansson, T., Lennan, M., Fernández, J., Echebarria, P., Aspasia, D.D. 2023. Introduction to Smart Ports and Robotic Systems: Navigating the Waves of Techno-Regulation and Governance. Available at: https://doi.org/10.1007/978-3-031-25296-9_1
- Jones, D., Gates, A., Huvenne, V., Phillips, A., Bett, B. 2019. 'Autonomous marine environmental monitoring: Application in decommissioned oil fields'. *Science of the Total Environment*, vol. 668, pp. 835–853. Available at: <https://doi.org/10.1016/j.scitotenv.2019.02.310>
- Jovanovic, V., Djuric, A., Karanovic, V., Stevanov, B. 2016. 'Applications of electro-hydraulics actuators'. *Conference Proceedings - IEEE SOUTHEASTCON*, 2016-July(March). Available at: <https://doi.org/10.1109/SECON.2016.7506678>
- Kaikkonen, L., Venesjärvi, R., Nygård, H., Kuikka, S. 2018. 'Assessing the impacts of seabed mineral extraction in the deep sea and coastal marine environments: Current methods and recommendations for environmental risk assessment'. *Marine Pollution Bulletin*, vol. 135, pp. 1183–1197. Available at: <https://doi.org/10.1016/j.marpolbul.2018.08.055>
- Karen, L.H. 2021. 'Deep-Sea Mining December', (December), pp. 21–22. Available at: <https://www.mdpi.com/2071-1050/17/14/6580>
- Karoliuss, K., Cichowicz, J., Løvoll, G., Jørgensen A. 2024 'Navigating the challenges of assuring safe autonomous navigation' Available at: https://www.researchgate.net/publication/385011929_Navigating_the_challenges_of_assuring_safe_autonomous_navigation
- Katona, K., Neamah, H.A., Korondi, P. 2024. 'Obstacle Avoidance and Path Planning Methods for Autonomous Navigation of Mobile Robot'. *Sensors*, vol. 24, no. 11. Available at: <https://doi.org/10.3390/s24113573>
- Keisner, A., Raffo, J., Wunsch-Vincent, S. 2016. 'Robotics: Breakthrough technologies, innovation, intellectual property'. *Foresight and STI Governance*, vol. 10, no. 2, pp. 7–27. Available at: <https://doi.org/10.17323/1995-459X.2016.2.7.27>
- Khalid, O., Hao, G., Desmond, C., Macdonald, H., McAuliffe, F.D., Dooly, G., Hu, W. 2022. 'Applications of robotics in floating offshore wind farm operations and maintenance: Literature review and trends'. *Wind Energy*, vol. 25, no. 11, pp. 1880–1899. Available at: <https://doi.org/10.1002/we.2773>
- Khan, W., Hua, W., Anwar, M., Shahid, A., Abdullah, I., Muhammad, K., Javed, A. 2022. 'An Effective Data-Collection Scheme with AUV Path Planning in Underwater Wireless Sensor Networks'. *Wireless Communications and Mobile Computing*. Available at: <https://doi.org/10.1155/2022/8154573>
- Kong, T., Ma, L., Ai, G. 2022. 'Research on Improving Satellite Positioning Precision Based on Multi-Frequency Navigation Signals'. *Sensors*, vol. 22, no. 11. Available at: <https://doi.org/10.3390/s22114210>
- Kovryzhenko, Y., Li, N., Taheri, E. 2024. 'Quadrotors with Real-Time Re-Planning Capability', pp. 1–27. Available at: [file:///C:/Users/mikeo/Downloads/A Control System Design and Implementation for Aut.pdf](file:///C:/Users/mikeo/Downloads/A%20Control%20System%20Design%20and%20Implementation%20for%20Aut.pdf)
- Kowalski, P. 2023. 'Energy Sector', *The Contemporary Russian Economy: A Comprehensive Analysis*, pp. 161–186. Available at: https://doi.org/10.1007/978-3-031-17382-0_9
- Kulathunga, G. 2022. 'A Reinforcement Learning based Path Planning Approach in 3D Environment'. *Procedia Computer Science*, vol. 212(C), pp. 152–160. Available at: <https://doi.org/10.1016/j.procs.2022.10.217>
- Kumar, A., Patel, M., Pardhi, B., Pal, M. 2020. 'Erosive and Corrosive Wear in Slurry Pumps-A Review Article'. *International Research Journal of Engineering and Technology* [Preprint], (April). Available at: <https://www.researchgate.net/publication/340535760>
- Larbey, R., Studley, M., Bird, E., Jenner, N., Fox-Skelly, J. 2021. 'Ethics of marine robots: report for the Net Zero Oceanographic Capability Project (NZOC), June 2021', Fmri.Ac.Uk [Preprint], (June). Available at: [https://fmri.ac.uk/sites/fmri/files/documents/NZOC_210623-Ethics of marine robots.pdf](https://fmri.ac.uk/sites/fmri/files/documents/NZOC_210623-Ethics_of_marine_robots.pdf)
- Lau, H.C., Song, H. 2008. 'Multi-echelon repairable item inventory system with limited repair capacity under nonstationary demands'. *International Journal of Inventory Research*, vol. 1, no 1, p. 67. Available at: <https://doi.org/10.1504/ijir.2008.019209>
- Leal Filho, W., Abubakar, I., Nunes, C., Platje, J., Ozuyar, P.G., Will, M., Nagy, G.J., Al-Amin, A.Q., Hunt, J.D., Li, C. 2021. 'Deep seabed mining: A note on some potentials and risks to the sustainable mineral extraction from the oceans'. *Journal of Marine Science and Engineering*, vol. 9, no. 5. Available at: <https://doi.org/10.3390/jmse9050521>
- Leal, F.W. 2021. 'Deep seabed mining: A note on some potentials and risks to the sustainable mineral extraction from the oceans', *Journal of Marine Science and Engineering*, vol. 9, no. 5, pp. 1–16. Available at: <https://doi.org/10.3390/jmse9050521>
- Lee, J., Kim, B., Sun, D., Han, C., Ahn, Y. 2019. 'Development of unmanned excavator vehicle system for performing dangerous construction work'. *Sensors*, vol. 19, no. 22. Available at: <https://doi.org/10.3390/s19224853>
- Lehmköster, J. 2022. 'Seafloor Mining', maribus GmbH, Pickhuben 2, D-20457 Hamburg, Germany, pp. 933–933. Available at: https://doi.org/10.1007/978-3-319-98536-7_300161
- Leong, P.Y., Ahmad, N.S. 2024. 'LiDar-based Obstacle Avoidance with Autonomous Vehicles: A Comprehensive Review'. *IEEE Access*, p. 1. Available at: <https://doi.org/10.1109/ACCESS.2024.3493238>
- Li, D., Wang, P., Du, L. 2019. 'Path planning technologies for autonomous underwater vehicles-a review'. *IEEE Access*, vol. 7, pp. 9745–9768. Available at: <https://doi.org/10.1109/ACCESS.2018.2888617>

A systematic review of hybrid quadrotor-track subsea robotic crawler for offshore mineral mining

- Li, G. 2023. 'Bioinspired soft robots for deep-sea exploration'. *Nature Communications*, vol. 14, no. 1, pp. 1–10. Available at: <https://doi.org/10.1038/s41467-023-42882-3>
- Li, J., Li XLu, J., Cao, B., Sun, J. 2024. 'A Novel Robust Hybrid Control Strategy for a Quadrotor Trajectory Tracking Aided with Bioinspired Neural Dynamics'. *Applied Sciences*, vol. 14, no. 20. Available at: <https://doi.org/10.3390/app14209592>
- Li, U., Liu, S. 2009. 'Modeling and simulation of active-controlled heave compensation system of deep-sea mining based on dynamic vibration absorber'. *IEEE International Conference on Mechatronics and Automation, ICMA 2009*, pp. 1337–1341. Available at: <https://doi.org/10.1109/ICMA.2009.5246738>
- Liu, L., Gai, K., Yang, J., Guo, X. 2022. 'Numerical Investigation on the Dynamics of Mixture Transport in Flexible Risers during Deep-Sea Mining'. *Journal of Marine Science and Engineering*, vol. 10, no. 12. Available at: <https://doi.org/10.3390/jmse10121842>
- Liu, Z., Liu, K., Chen, X., Ma, Z., Lv, R., Wei, C., Ma, K. 2023. 'Deep-sea rock mechanics and mining technology: State of the art and perspectives'. *International Journal of Mining Science and Technology*, vol. 33, no. 9, pp. 1083–1115. Available at: <https://doi.org/10.1016/j.ijmst.2023.07.007>
- Liu, Z.X., Wang, Q., Yang, B. 2022. 'Reinforcement Learning-Based Path Planning Algorithm for Mobile Robots'. *Wireless Communications and Mobile Computing*, 2022. Available at: <https://doi.org/10.1155/2022/1859020>
- Loginov, A., Proskurnikov, A., Ambrosovskaya, E., Romaev, D. 2012. 'DP systems for track control of dredging vessels'. *IFAC Proceedings Volumes (IFAC-PapersOnline)*, vol. 9(PART 1), pp. 453–458. Available at: <https://doi.org/10.3182/20120919-3-IT-2046.00077>
- Lu, Q., Yue, Q., Yang, Z., Wang, G., Yan, J., Qu, Y. 2012. 'Cross-sectional layout analysis of steel tube umbilical'. *Proceedings of the International Conference on Offshore Mechanics and Arctic Engineering - OMAE*, pp. 493–497. Available at: <https://doi.org/10.1115/OMAE2012-83572>
- Luo, Z., Zhang, Y., Mu, L., Huang, J., Xin, J., Liu, H., Jiao, S., Xie GYi, Y. 2020. 'A UAV Path Planning Algorithm Based on an Improved D* Lite Algorithm for Forest Firefighting'. *Proceedings - 2020 Chinese Automation Congress, CAC 2020*, (November), pp. 4233–4237. Available at: <https://doi.org/10.1109/CAC51589.2020.9327111>
- Lutsey, N., Meszler, D., Isenstadt, A., German, J., Miller, J. 2017. 'Efficiency Technology and Cost Assessment for U.S. 2025–2030 Light-Duty Vehicles'. *The International Council on Clean Transportation*, p. 11. Available at: <https://doi.org/10.13140/RG.2.2.13344.99841>
- Ma, S., Flanigan, K.A., Bergés, M. 2024. 'State-of-the-Art Review: The Use of Digital Twins to Support Artificial Intelligence-Guided Predictive Maintenance', (January). Available at: <https://doi.org/10.48550/arXiv.2406.13117>
- Ma, W., Schott, D., Lodewijks, G. 2017. 'A research procedure to obtain a green transport plan for deep sea mining systems'. *Proceedings of the International Offshore and Polar Engineering Conference*, pp. 22–29. Available at: https://www.researchgate.net/publication/359045924_A_Research_Procedure_to_Obtain_A_Green_Transport_Plan_for_Deep_Sea_Mining_Systems
- MacDiarmid, A., Boschen, R., Bowden, D., Clark, M., Hadfield, M., Lamarche, G., Nodder, S., Pinkerton, M., Thompson, D. 2014. 'Environmental risk assessment of discharges of sediment during prospecting and exploration for seabed minerals'. *NIWA Client Report*, (WLG2013-66), p. 53. Available at: <https://environment.govt.nz/assets/Publications/Files/environment-risk-assessment-discharges-sediment-niwa-report-pdf.pdf>
- Mackenzie, R., Roux, C., Baume, A., Allstaff, E., Pimentel, J. 2016. 'All Electric Subsea Production System – A World First', MCE Deepwater Development 2016 [Preprint], (April 2016). Available at: https://deepwaterexecsummit.com/wp-content/uploads/01_Rory%20MacKenzie%20-%20Total.pdf
- Mai, C., Chen, H., Zeng, L., Li ZLiu, G., Qiao ZQu, Y., Li LLi, L. 2024. 'A Smart Cane Based on 2D LiDAR and RGB-D Camera Sensor-Realizing Navigation and Obstacle Recognition'. *Sensors*, vol. 24, no. 3. Available at: <https://doi.org/10.3390/s24030870>
- Mansouri, M., Harkat, M., Nounou, H., Nounou, M. 2020. 'Data-Driven and Model-Based Methods for Fault Detection and Diagnosis', *Data-Driven and Model-Based Methods for Fault Detection and Diagnosis*, (July 2019), pp. 1–295. Available at: <https://doi.org/10.1016/C2018-0-04213-9>
- Manufacturing, A.W.G. 2024. 'Cloud-Edge-IoT Continuum : opportunities and challenges for the Manufacturing Industry', (December), pp. 1–100. Available at: <https://aioti.eu/wp-content/uploads/CEI-Continuum-opportunities-and-challenges-for-Manufacturing-Final.pdf>
- Marijan, D., Sen, S. 2018. 'Devops enhancement with continuous test optimization'. *Proceedings of the International Conference on Software Engineering and Knowledge Engineering, SEKE, 2018-July(February)*, pp. 536–541. Available at: <https://doi.org/10.18293/SEKE2018-168>
- Maus, V., Giljum, S., da Silva, D., Gutschlhofer, J., da Rosa, R.P., Luckeneder, S., Gass, S.L.B., Lieber, M., McCallum, I. 2022. An update on global mining land use'. *Scientific Data*, vol. 9, no. 1, pp. 1–11. Available at: <https://doi.org/10.1038/s41597-022-01547-4>
- Mawali, N.R, Lawati, A.M., Ananda, S. 2021. Fourth Industrial Revolution and Business Dynamics: Issues and Implications. Available at: <https://doi.org/10.1007/978-981-16-3250-1>
- Meftah, L.H., Cherif, A., Braham, R. 2024. 'Improving Autonomous Vehicles Maneuverability and Collision Avoidance in Adverse Weather Conditions Using Generative Adversarial Networks'. *IEEE Access*, vol. 12, pp. 89679–89690. Available at: <https://doi.org/10.1109/ACCESS.2024.3419029>
- Mendez, J., Molina, M., Rodriguez, N., Cuellar, M., Morales, D. 2021. 'Camera-lidar multi-level sensor fusion for target detection at the network edge'. *Sensors*, vol. 21, no. 12, pp. 1–14. Available at: <https://doi.org/10.3390/s21123992>
- Menges, D., Von Brandis, A., Rasheed, A. 2024. 'Digital Twin for Autonomous Surface Vessels for Safe Maritime Navigation', pp. 1–10.
- Meszler, D., Lutsey, N., Delgado, O. 2020. 'Long-haul tractor-trailers in the 2020–2030 time frame', April 2015.
- Metaxas, A., Anglin, C., Cross, A., Drazen, J., Haeckel, M., Mudd, G., Smith, C., Smith, S., Weaver, P., Sonter, L., Amon, D., Erskine, P., Levin, L., Lily, H., Maest, A., Mestre, N., Ramirez-Llodra Esánchez, L., Sharma, R., Vanreusel, A., Whetton, S., Tunnicliffe. 2024. 'Comparing environmental impacts of

A systematic review of hybrid quadrotor-track subsea robotic crawler for offshore mineral mining

- deep-seabed and land-based mining: A defensible framework'. *Global Change Biology*, vol. 30, no. 5. Available at: <https://doi.org/10.1111/gcb.17334>
- Mikołajczyk, T., Mikołajewski, D., Kłodowski, A., Łukaszewicz, A., Mikołajewska, E., Paczkowski, T., Macko, M., Skornia, M. 2023. 'Energy Sources of Mobile Robot Power Systems: A Systematic Review and Comparison of Efficiency'. *Applied Sciences*, vol. 13, no. 13. Available at: <https://doi.org/10.3390/app13137547>
- Min, C., Si, S., Wang, X., Xue, H., Jiang, W., Liu, Y., Wang, J., Zhu, Q., Zhu, Q., Luo, L., Kong, F., Miao, J., Cai, X., An SLi, W., Mei, J., Sun, T., Zhai, H., Liu, Q., Zhao, F., Chen, L., Wang, S., Shang, E., Shang, L., Zhao, K., Li, F., Fu, H., Jin, L., Zhao, J., Mao, F., Ministry, D., Agency, E., Environmental, D., Agency, P., Epa, D. 1996 'Midas An example of an environmental data strategy', February.
- Mitchell, D., Blanche, J., Harper, S., Lim, T., Gupta, R., Zaki, O., Tang, W., Robu, V., Watson, S., Flynn D. 2022. 'A review: Challenges and opportunities for artificial intelligence and robotics in the offshore wind sector'. *Energy and AI*, vol. 8, pp. 1–49. Available at: <https://doi.org/10.1016/j.egyai.2022.100146>
- Mohapatra, A. 2024. 'Generative AI for Predictive Maintenance: Predicting Equipment Failures and Optimizing Maintenance Schedules Using AI', vol. 12, no. 11, pp. 1648–1672. Available at: <https://doi.org/10.18535/ijstrm/v12i11.ec03>
- Moher, D., Liberati, A., Tetzlaff, J., Altman, D., 2009 'Preferred reporting items for systematic reviews and meta-analyses: The PRISMA statement'. *BMJ (Online)*, 339(7716), pp. 332–336. Available at: <https://doi.org/10.1136/bmj.b2535>
- Molaei, F., Rahimi, E., Siavoshi, H., Afrouz, S., Tenorio, V. 2020. 'A Comprehensive Review on Internet of Things (IoT) and its Implications in the Mining Industry'. *American Journal of Engineering and Applied Sciences*, vol. 13, no.3, pp. 499–515. Available at: <https://doi.org/10.3844/ajeassp.2020.499.515>
- Moloney, L. 2006. 'The many challenges of parenting'. *Journal of Family Studies*, vol. 12, no. 2, pp. 161–164. Available at: <https://doi.org/10.5172/jfs.327.12.2.161>
- Munir, A., Blasch, E., Kwon, J., Kong, J., Aved, A. 2021. 'Artificial Intelligence and Data Fusion at the Edge'. *IEEE Aerospace and Electronic Systems Magazine*, vol. 36, no. 7, pp. 62–78. Available at: <https://doi.org/10.1109/MAES.2020.3043072>
- Murdock, R. 2023 'Deep Sea Mining and the Green Transition'. *Harvard International Review*, vol. 7, no. 3, pp. 21–27. Available at: <https://hir.harvard.edu/deep-sea-mining-and-the-green-transition/>
- Muthugala, M., Palanisamy, P., Samarakoon, S., Padmanabha, S., Elara Mterntzer, D. 2021. 'Raptor: A design of a drain inspection robot'. *Sensors*, vol. 21, no. 17. Available at: <https://doi.org/10.3390/s21175742>
- Naga, B., Vandavasi, J., Arunachalam, U., Vittal DRaju, R., Narayanaswamy, V., Arumugam, V., Sethuraman, R., Gidugu, A. 2023. *AI - ML-Enabled Electromagnetic Homing*. vol. 57, no. 1, pp. 7–15.
- Nakano, J. 2025. 'Baskaran_Critical_Minerals.pdf'. Gracelin Baskaran. Available at: https://csis-website-prod.s3.amazonaws.com/s3fs-public/2025-02/250210_Baskaran_Critical_Minerals.pdf?VersionId=Tfu2TnNrQGIn7o18HSCakMUT8HTwYukd
- NOAA Office of Ocean and Coastal Resource Management 2010. 'Adapting to Climate Change: A Planning Guide for State Coastal Managers'. *Management*, p. 138. Available at: <http://coastalmanagement.noaa.gov/climate/adaptation.html>
- Nordin, M., Sharma, S., Khan, A., Gianni, M., Rajendran, S., Sutton, R. 2022. 'Collaborative Unmanned Vehicles for Inspection, Maintenance, and Repairs of Offshore Wind Turbines'. *Drones*, vol. 6, no. 6, pp. 1–26. Available at: <https://doi.org/10.3390/drones6060137>
- Ocean Trustee Implementation Group 2019. 'Open Ocean TIG Restoration Plan 2 and Environmental Assessment: Fish, Sea Turtles, Marine Mammals, and Mesophotic and Deep Benthic Communities', p. 493. Available at: <https://www.gulfspillrestoration.noaa.gov/restoration-planning/gulf->
- Ojha, T., Raptis, T., Passarella, A., Conti, M. 2023. 'Wireless power transfer with unmanned aerial vehicles: State of the art and open challenges'. *Pervasive and Mobile Computing*, vol. 93, p. 101820. Available at: <https://doi.org/10.1016/j.pmcj.2023.101820>
- Ojumu, M.O. 2022. The development of an electric-powered subsea robotic crawler for dredging. Available at: https://etd.cput.ac.za/bitstream/20.500.11838/3728/1/Ojumu_Mike_Oluwaseun_217269680.pdf
- Okereke, C., Wahab, N., Mohamad, M., Zaleha S. 2021. 'Autonomous Underwater Vehicle in Internet of Underwater Things: A Survey'. *Journal of Physics: Conference Series*, vol. 2129, no. 1. Available at: <https://doi.org/10.1088/1742-6596/2129/1/012080>
- Oladele, S. 2025. 'The Rise of Autonomous Robots : AI-Driven Navigation and Control', (January).
- Olanrewaju, O.I.K., Daramola, G.O., Babayeju, O.A. 2024. 'Harnessing big data analytics to revolutionize ESG reporting in clean energy initiatives'. *World Journal of Advanced Research and Reviews*, vol. 22, no. 3, pp. 574–585. Available at: <https://doi.org/10.30574/wjarr.2024.22.3.1759>
- Olivart I Llop, J.M., Moreno-Salinas, D., Sánchez, J. 2020. 'Full real-time positioning and attitude system based on gnss-rtk technology'. *Sustainability*, vol. 12, no. 23, pp. 1–21. Available at: <https://doi.org/10.3390/su12239796>
- Olsson, A. 2021. 'Design and development of a submersible UAV', (2021:337).
- Oluleye, G. 2021. 'Environmental Impacts of Mined Diamonds'. Available at: <https://www.imperial-consultants.co.uk/wp-content/uploads/2021/02/Final-report-Environmental-Impacts-of-Mined-Diamonds.pdf>
- Oluokun, O., Akinsooto, O., Ogundipe, O., Ikemba, S. 2025. 'Energy Efficiency in Mining Operations: Policy and Technological Innovations Energy Efficiency in Mining Operations: Policy and Technological Innovations Received: 12-12-2023 Accepted 18-01-2024 Page No: 994-1008', (January). Available at: <https://doi.org/10.54660/IJMRGE.2024.5.1.994-1008>
- Olusegun, J. 2025. 'Adaptive Control Strategies in Autonomous Vehicles Using Reinforcement Learning', (January).
- Özenir, İpek, G.N. 2022. Industry 4 . 0 in Manufacturing.
- Pallavi, C.H., Sreenivasulu, G. 2021. 'A high speed underwater wireless communication through a novel hybrid opto-acoustic modem using MIMO-OFDM'. *Instrumentation Mesure Metrologie*, vol. 20, no. 5, pp. 279–287. Available at: <https://doi.org/10.18280/im.200505>

A systematic review of hybrid quadrotor-track subsea robotic crawler for offshore mineral mining

- Pandey, A. 2016. 'Multiple Mobile Robots Navigation and Obstacle Avoidance Using Minimum Rule Based ANFIS Network Controller in the Cluttered Environment'. *International Journal of Advanced Robotics and Automation*, vol. 1, no. 1, pp. 1–11. Available at: <https://doi.org/10.15226/2473-3032/1/1/00102>
- Pandey, A. 2017. 'Mobile Robot Navigation and Obstacle Avoidance Techniques: A Review'. *International Robotics & Automation Journal*, vol. 2, no. 3, pp. 96–105. Available at: <https://doi.org/10.15406/iratj.2017.02.00023>
- Paramesha, M., Rane, N., Rane, J. 2024. 'Big data analytics, artificial intelligence, machine learning, internet of things, and blockchain for enhanced business intelligence'. *SSRN Electronic Journal*, pp. 110–133. Available at: <https://doi.org/10.2139/ssrn.4855856>
- Parvin, K., Lipu, M., Hannan, M., Abdullah, M., Jern, K., Begum, R., Mansur, M., Muttaqi, K., Mahlia, T., Dong, Z. 2021 'Intelligent Controllers and Optimization Algorithms for Building Energy Management towards Achieving Sustainable Development: Challenges and Prospects'. *IEEE Access*, pp. 41577–41602. Available at: <https://doi.org/10.1109/ACCESS.2021.3065087>
- Paull, L., Sajad, S., Mae Seto, H.L. 2013. 'AUV Navigation and Localization Defence Research and Development Canada – Atlantic', (January), p. 30. Available at: <https://scispace.com/pdf/auv-navigation-and-localization-a-review-2aaowbjv0i.pdf>
- Pham, K., Leuchter, J., Bystricky, R., Andrie, M., Pham, N., Pham, V. 2022. 'The Study of Electrical Energy Power Supply System for UAVs Based on the Energy Storage Technology'. *Aerospace*, vol. 9, no. 9. Available at: <https://doi.org/10.3390/aerospace9090500>
- Potter, K., Doris, L. 2024. 'Predictive Maintenance for Electric Vehicles: Enhancing Reliability and Efficiency', vol. 11, no. 12, pp. 25647–25661. Available at: <https://doi.org/10.18535/ijecs/v11i12.4713>
- Prabu, S., Senthilraja, R., Ali, A., Jayapoorani, S., Arun, M. 2025. 'AI-Driven Predictive Maintenance for Smart Manufacturing Systems Using Digital Twin Technology', vol. 11, no. 1, pp. 1350–1355. Available at: <https://doi.org/10.22399/ijcesen.1099>
- President, T., Greve, H. 2022. 'Press release Arctic Canadian Diamond Company and IHC Mining jointly developing innovative Underwater Remote Mining system Press release', pp. 4–7
- Prozessindustrie, V.K. Der. 2025. 'Reference Architecture for AI solutions' application within process industry – the EU project s-X-AIPI experience' Available at: https://www.cencenelec.eu/media/CEN-CENELEC/News/Workshops/2025/2025-02-17-AIPI/cwa_referencearchitecture-ai_processindustry_s-x-aiipi_v2-0.pdf
- Pump, H.S. 2022. 'Hydril Subsea Pump', p. 2022. Available at: <https://hnhw.com/wp-content/uploads/2022/05/Rebrand-3-GE-Subsea-Pump.pdf>
- Puppet Labs 2015. '2015 State of DevOps Report', Puppetlabs, (877), p. 37. Available at: <https://doi.org/10.13140/RG.2.1.3890.2645>
- Qiong, H., Zhenfu, L., Zhai, X., Zheng, Hao. 2022. 'Development of Hydraulic Lifting System of Deep-Sea Mineral Resources'. *Minerals*, vol. 12, no. 10. Available at: <https://doi.org/10.3390/min12101319>
- Rajesh, S., Hanbhag, R., Dasi, U., Singla, N., Balasubramanian, R., Benadikar, S. 2023 'Intelligent Systems and Applications in Engineering Exploring the Use of Cloud-Based AI and ML for Real-Time Anomaly Detection and Predictive Maintenance in Industrial IoT Systems'
- Ramachandran, A. 2025. 'The Rise of Autonomous UAV Swarms: Harnessing Advanced AI for Breakthrough Applications, Challenges, and Future Directions'. Available at: https://www.researchgate.net/publication/388357951_The_Rise_of_Autonomous_UAV_Swarms_Harnessing_Advanced_AI_for_Breakthrough_Applications_Challenges_and_Future_Directions
- Rao, T. 2021. 'of ASIC / FPGA Verification IP and Interoperability of ASIC / FPGA Verification IP'
- Rashid, A.B., Kausik, M.A.K. 2024. 'AI revolutionizing industries worldwide: A comprehensive overview of its diverse applications'. *Hybrid Advances*, vol. 7, p. 100277. Available at: <https://doi.org/10.1016/j.hybadv.2024.100277>
- Raza, F. 2024. 'AI for Predictive Maintenance in Industrial Systems'. *Cosmic Bulletin of Business Management*, 2 November, p. 1. Available at: <https://doi.org/10.13140/RG.2.2.27313.35688>
- Recalde, A., Cajo, R., Velasquez, W. Alvarez-Alvarado, M. 2024. 'Machine Learning and Optimization in Energy Management Systems for Plug-In Hybrid Electric Vehicles: A Comprehensive Review'. *Energies*, vol. 17, no. 13. Available at: <https://doi.org/10.3390/en17133059>
- Report, F. 2015. 'Multi-Modal Intelligent Traffic Signal Systems (MMITSS) Impacts Assessment'
- Robinson, L., Hammitt, J., Zeckhauser, R. 2014 'The Role of Distribution in Regulatory Analysis and Decision Making', pp. 1–30. Available at: www.hks.harvard.edu/mrcbg
- Roland Holst, R.J. 2024 'Exploiting the deep seabed for the benefit of humankind: A universal ideology for sustainable resource development or a false necessity?'. *Leiden Journal of International Law*, vol. 37, no. 2, pp. 400–422. Available at: <https://doi.org/10.1017/S092215652300064X>
- Romero, O.J., Hupp, A. 2014 'Subsea electrical submersible pump significance in petroleum offshore production'. *Journal of Energy Resources Technology, Transactions of the ASME*, vol. 136, no. 1. Available at: <https://doi.org/10.1115/1.4025258>
- Ross, S., Hill, J., Chen, M., Joseph, A., Culler, D., Brewer, E. 2000. 'A composable framework for secure multi-modal access to Internet services from post-PC devices'. *Proceedings - 3rd IEEE Workshop on Mobile Computing Systems and Applications, WMCSA 2000*, pp. 171–182. Available at: <https://doi.org/10.1109/MCSA.2000.895392>
- Saeedi, S., Nagaty, A., Thibault, C., Trentini, M., Li, H. 2016 'Perception and navigation for an autonomous quadrotor in GPS-denied environments'. *International Journal of Robotics and Automation*, vol. 31, no. 6, pp. 453–463. Available at: <https://doi.org/10.2316/Journal.206.2016.6.206-4434>
- Saganiak, K., Buketov, V. 2024 'Integrating mining software, CAD, and GIS technologies for enhanced 3D geological mapping and visualization'. *E3S Web of Conferences*, vol. 567. Available at: <https://doi.org/10.1051/e3sconf/202456701021>
- Sah, B.P., Tanha, N.I., Sikder, M., Habibullah, S. 2024. The Integration of Industry 4.0 and Lean Technologies in Manufacturing Industries. *A Systematic Literature Review*, vol 1, no. 3, pp. 14–25. Available at: <https://doi.org/10.62304/ijmisd.v1i3.164>
- Sakic, P., Chupin, C., Ballu, V., Coulombier, T., Morvan, P., Urvoas, P., Beauverger, M., Royer, J. 2021 'Geodetic Seafloor Positioning

A systematic review of hybrid quadrotor-track subsea robotic crawler for offshore mineral mining

- Using an Unmanned Surface Vehicle—Contribution of Direction-of-Arrival Observations'. *Frontiers in Earth Science*, 9. Available at: <https://doi.org/10.3389/feart.2021.636156>
- Saneian, M., Gao, Y., Bai, Y., Liu T. 2019 'Analysis of subsea umbilical mechanical behavior under simultaneous bending, tension and torsion'. *Proceedings of the International Conference on Offshore Mechanics and Arctic Engineering - OMAE*, 5A-2019 (June). Available at: <https://doi.org/10.1115/OMAE2019-96596>
- Sanghavi, D., Parikh, S., Raj, S.A. 2019. 'Industry 4.0: Tools and implementation'. *Management and Production Engineering Review*, vol. 10, no. 3, pp. 3–13. Available at: <https://doi.org/10.24425/mper.2019.129593>
- Saoud, B., Shayea, I., Yahya ASHamsan, Z., Alhammadi, A., Alawad, M., Alkhrijah, Y. 2024. 'Artificial Intelligence, Internet of things and 6G methodologies in the context of Vehicular Ad-hoc Networks (VANETs). *Survey ICT Express*, vol. 10, no. 4, pp. 959–980. Available at: <https://doi.org/10.1016/j.icte.2024.05.008>
- Saravanakumar, Y., Sultan, M., Shahar, F., Giernacki, W., Łukaszewicz, A., Nowakowski, M., Holovaty, A., Stepień, S. 2023. 'Power Sources for Unmanned Aerial Vehicles: A State-of-the Art'. *Applied Sciences*, vol. 13, no. 21. Available at: <https://doi.org/10.3390/app132111932>
- Sazonov, Y., Mokhov, M., Gryaznova, I., Tumanyan, K., Pyatibratov, P., Voronova, V. 2020 'Development and research of jet pump-compressor unit with periodical connection of ejector'. *Journal of Applied Engineering Science*, vol. 18, no. 2, pp. 267–272. Available at: <https://doi.org/10.5937/jaes18-25998>
- Schmidt, M., Ahlström, S. 2024. 'Collaborative slam for ground robotics in search and rescue missions'.
- Seabed Dredging Excavator and Seascape Technology BV. 2017. SBDE - Seabed dredger excavator. (Accessed: 26 August 2021) Available at: <https://www.seascapesubsea.com/project-details/seabed-dredger-excavator/>
- Seabed Technology 2022. 'International Seabed Authority: Seabed Technology', p. 4. Available at: <https://www.proceedings.com/content/049/049748webtoc.pdf>
- Shadravan, A.R. Parsaei, H. 2024 'Industry 4.0 Readiness: From Concept to Implementation', pp. 2210–2217. Available at: <https://doi.org/10.46254/an14.20240588>
- Sharma, R. 2011. 'Deep-sea mining: Economic, technical, technological, and environmental considerations for sustainable development'. *Marine Technology Society Journal*, vol. 45, no. 5, pp. 28–41. Available at: <https://doi.org/10.4031/MTSJ.45.5.2>
- Sharma, R. 2015. 'Environmental Issues of Deep-Sea Mining'. *Procedia Earth and Planetary Science*, vol. 11, pp. 204–211. Available at: <https://doi.org/10.1016/j.proeps.2015.06.026>
- Sharmilan, T., Abeysekara, N. 2024. 'Development and Enhancement of Autonomous Mobile Robots Using Reinforcement Learning : Improving Navigation and Obstacle Avoidance in Small-Scale Industrial Settings', (August). Available at: <https://doi.org/10.20944/preprints202408.1849.v1>
- Shi, W., Mestemaker, B., Den Boer, L., Contessi, C., Zotti, A. 2015. 'Application of Lng Df Engines in Dredging Vessels', (November 2015), pp. 1–12
- Shields, M.D. , Young, S.M. 1989. 'A behavioral model for implementing cost management systems'. *Journal of Cost Management*, (Winter), pp. 17–27
- Shin, J.H., Jun, H.B. 2015. 'On condition based maintenance policy'. *Journal of Computational Design and Engineering*, vol. 2, no. 2, pp. 119–127. Available at: <https://doi.org/10.1016/j.jcde.2014.12.006>
- Sikdar, B. 2018. *Proceedings of the 3rd International Conference on Informatics and Computing, ICIC2018* Available at: <https://www.proceedings.com/content/049/049748webtoc.pdf>
- Soderbaum, P. 2020. 'Environmental and Other Problems'. *Ecological Economics*, (November), pp. 17–33. Available at: <https://doi.org/10.4324/9781315071640-9>
- Sola, Y. 2022. 'Contributions to the development of deep reinforcement learning-based controllers for AUV Yoann Sola To cite this version: HAL Id : tel-03901160 Yoann SOLA Contributions to the development of Deep Reinforcement'
- Soldatos, J., Kyriazis, D. 2021. Trusted Artificial Intelligence in Manufacturing: A Review of the Emerging Wave of Ethical and Human Centric AI Technologies for Smart Production. Available at: https://www.researchgate.net/publication/356788493_Trusted_Artificial_Intelligence_in_Manufacturing_A_Review_of_the_Emerging_Wave_of_Ethical_and_Human_Centric_AI_Technologies_for_Smart_Production
- Song, H., Zhang, D. 2023. 'Frontiers in Computing and Intelligent Systems Robot Path Planning Algorithm based on Improved A* and DWA', vol. 6, no. 1, pp. 3–7
- Stella, C., Little, A.D. 2024. 'Seabed Mining : A \$20 TRILLION OPPORTUNITY The future of resource extraction ' Available at: <https://www.adlittle.com/en/insights/viewpoints/seabed-mining-20-trillion-opportunity>
- Stevens, B., Jolly, C. 2021. 'FOR OCEAN', (September). Available at: <https://doi.org/10.1787/a4734a65-en>
- Stimmel, C.L. 2016. Big Data Analytics Strategies for the Smart Grid. Available at: <https://doi.org/10.1201/b17228>
- Su, X., Tang, Z., Li, Y., Zhu, Z., Mianowicz, K., Balaz, P. 2020. 'Research of particle motion in a two-stage slurry transport pump for deep-ocean mining by the CFD-DEM method'. *Energies*, vol. 13, no. 24. Available at: <https://doi.org/10.3390/en13246711>
- Sugiura, L., Wiles, R., Pope, C. 2017. 'Ethical challenges in online research: Public/private perceptions'. *Research Ethics*, vol. 13, no. 3–4, pp. 184–199. Available at: <https://doi.org/10.1177/1747016116650720>
- Sulaiman, H., Saadun, M.N.A., Yusof, A.A. 2015. 'Modern Manned, Unmanned and Teleoperated Excavator System'. *Journal of Mechanical Engineering and Technology*, vol. 7, no. 1, pp. 57–68.
- Sulaiman, H., Yusof, A.A., Noor, M., Saadun, A., Sabaruddin, S.A. 2016. 'Simulation of Tele-Operated Electro-Hydraulic Actuator and Excavator ' s Boom', (January).
- Sumaila, U.R., Alam, L., Pradhoshini, K., Onifade, T., Karuaihe, S.T., Singh, P., Levin, L.A., Flint, R. 2023. 'To engage in deep-sea mining or not to engage: what do full net cost analyses tell us?'. *npj Ocean Sustainability*, vol. 2, no. 1. Available at: <https://doi.org/10.1038/s44183-023-00030-w>
- Sun, D., Jamshidnejad, A., De Schutter, B. 2024. 'Adaptive parameterized model predictive control based on reinforcement learning: A synthesis framework'. *Engineering Applications of Artificial Intelligence*, vol. 136(PB), p. 109009. Available at: <https://doi.org/10.1016/j.engappai.2024.109009>
- Sun, J. 2019. Open Aircraft Performance Modeling Based on an Analysis of Aircraft Surveillance Data, TU Delft University. Available at: <https://doi.org/10.4233/uuid>

A systematic review of hybrid quadrotor-track subsea robotic crawler for offshore mineral mining

- Sun, J., Zhang, Q., Lu, Y., Huang, B., Li, Q. 2025. 'A Review of Touching-Based Underwater Robotic Perception and Manipulation'. *Machines*, vol. 13, no. 1, pp. 1–22. Available at: <https://doi.org/10.3390/machines13010041>
- Sun, L., Wang, Y., Hui, X., Ma, X., Bai, X., Tan, M. 2024. 'Underwater Robots and Key Technologies for Operation Control'. *Cyborg and Bionic Systems*, vol. 5. Available at: <https://doi.org/10.34133/cbsystems.0089>
- Sun, X., Liu, F., Zhao, Y., Liu, F., Wang, J., Zhu, S., He, Q., Bai, Y., Zhang, J. 2024. 'Research on Environmental Risk Monitoring and Advance Warning Technologies of Power Transmission and Distribution Projects Construction Phase'. *Sensors*, vol. 24, no. 23, pp. 1–32. Available at: <https://doi.org/10.3390/s24237695>
- Svensson, L. 2018. 'Trajectory generation for safe overtaking maneuver in autonomous vehicles Evaluated in lane merging scenario utilizing a trajectory planner'.
- Swire Seabed. 2008. 'Seabed Excavator', pp. 1–2. (Accessed: 24 August 2021). Available at: www.swirseabed.com
- Tamunodukobipi, D., Nitonye, S., Adumene, S. 2018. 'Analysis of a Self-Propelled Dredger Capability in Shallow Waters Operation'. *International Journal of Recent Engineering Science*, vol. 5, no. 2, pp. 4–9. Available at: <https://doi.org/10.14445/23497157/ijres-v5i2p102>
- Teixeira, A., Shames, I., Sandberg, H., Johansson, K.H. 2014. 'Distributed fault detection and isolation resilient to network model uncertainties'. *IEEE Transactions on Cybernetics*, vol. 44, no. 11, pp. 2024–2037. Available at: <https://doi.org/10.1109/TCYB.2014.2350335>
- Thomas, J.J., King, J. 2023. 'Offshore Hybrid Energy Systems'. Available at: <https://www.nrel.gov/docs/fy23osti/86200.pdf>
- Thomson, A., Abadi, D.J.s 2013. 'Modularity and Scalability in Calvin'. *Data Engineering*, pp. 48–55. Available at: <http://sites.computer.org/debull/A13june/A13JUN-CD.pdf#page=50>
- Tiwari, R., Srinivaas, A., Velamati, R.K. 2025. 'Adaptive Navigation in Collaborative Robots: A Reinforcement Learning and Sensor Fusion Approach'. *Applied System Innovation*, vol. 8, no. 1. Available at: <https://doi.org/10.3390/asi8010009>
- Toledano, P., Points, K., Carreau, S., Kim, E. 2012. 'CCSI Policy Paper Leveraging the Mining Industry's Energy Demand to Improve Host Countries' Power Infrastructure Table of Contents', (September).
- Toledano, P., Ramdoo, I., Cosbey, A., Geipel, J. 2022. 'New Tech, New Deal: Mining Policy Options in the Face of New Technology'. SSRN Electronic Journal [Preprint], (May). Available at: <https://doi.org/10.2139/ssrn.4045058>
- Tong, F., Zhou, Y., Chen, D., Li, J., Zhang, X. 2023. 'Advances and trends of underwater acoustic communication technology for heterogeneous unmanned underwater vehicles'. *Harbin Gongcheng Daxue Xuebao/Journal of Harbin Engineering University*, vol. 44, no. 11, pp. 1963–1976. Available at: <https://doi.org/10.11990/jheu.202307040>
- Tooling, S., Uk, S., Services, S., Subsea, A., Services, T. 2018. 'Subsea Tooling Services Range of Dredgers Subsea Tooling Services Dredger Configuration'.
- Toteff, J., Asuaje, M., Noguera, R. 2022. 'New Design and Optimization of a Jet Pump to Boost Heavy Oil Production'. *Computation*, vol. 10, no. 1. Available at: <https://doi.org/10.3390/computation10010011>
- U.S. Department of Energy (2019) 'Exploring Opportunities for Marine Renewable Energy in Maritime Markets', (April), p. 170. Available at: <https://www.ocean-energy-systems.org/about-oes/what-is-ocean-energy/>
- Ucar, A., Karakose, M., Kırımça, N. 2024. Artificial Intelligence for Predictive Maintenance Applications: Key Components, Trustworthiness, and Future Trends. <https://www.mdpi.com/2076-3417/14/2/898>
- Ukoba, K., Olatunji, K.O., Adeoye, E., Jen, T.-C., Madyira, D.M. 2024. 'Optimizing renewable energy systems through artificial intelligence: Review and future prospects'. *Energy and Environment* [Preprint], (May). Available at: <https://doi.org/10.1177/0958305X241256293>
- Ummah, M.S. 2019a. 'SISTEM PEMBETUNGAN TERPUSAT: STRATEGI MELESTARIKAN PENGURUSAN KUMBAHAN Title, Sustainability (Switzerland). Available at: https://www.researchgate.net/publication/305320484_SISTEM_PEMBETUNGAN_TERPUSAT_STRATEGI_MELESTARIKAN_PENGURUSAN_KUMBAHAN
- Ummah, M.S. 2019b. 'SISTEM PEMBETUNGAN TERPUSAT: STRATEGI MELESTARIKAN PENGURUSAN KUMBAHAN', Sustainability (Switzerland), 11(1), pp. 1–14. Available at: https://www.researchgate.net/publication/305320484_SISTEM_PEMBETUNGAN_TERPUSAT_STRATEGI_MELESTARIKAN_PENGURUSAN_KUMBAHAN
- Underwater, Ix. 2014. 'iXBlue Positioning Solutions your data deserves the best positioning', (August). Available at: https://scripps.ucsd.edu/system/files/2021-01/2015-04-iXBlue_underwater_positioning_solutions.pdf
- Van Dover, C., Ardrion, J., Escobar, E., Gianni, M., Gjerde, K., Jaeckel, A., Jones, D., Levin, L., Niner, H., Pendleton, L., Smith, C., Thiele, T., Turner, P., Watling, L., Weaver, P. 2017. 'Biodiversity loss from deep-sea mining'. *Nature Geoscience*, vol. 10, no. 7, pp. 464–465. Available at: <https://doi.org/10.1038/ngeo2983>
- Vassileva, S., Doukovska, L., Sgurev, V. 2014. 'AI-based diagnostics for fault detection and isolation in process equipment service'. *Computing and Informatics*, vol. 33, no. 2, pp. 387–409.
- Venter, J., Sabunet. 2017. 'Hydraulic valve lifters', (January), p. 2017. Available at: <https://journals.co.za/doi/abs/10.10520/EJC-4d0eea0c7>
- Vercrujssje, P.M., Lotman, R. 2010. 'An integral design approach for deep sea mining systems using dredging technology. *Proceedings of the International Conference on Offshore Mechanics and Arctic Engineering - OMAE*, 3 (November), pp. 23–28. Available at: <https://doi.org/10.1115/OMAE2010-20238>
- Verma, M. 2024. 'Deep Sea Mining : Balancing Opportunities and Challenges for Sustainable Deep Sea Mining: Balancing Opportunities and Challenges for Sustainable Resource Extraction', (July).
- Vision, T. 2025a. 'AI : A Declaration of Autonomy'. Available at: https://www.accenture.com/content/dam/accenture/final/accenture-com/document-3/Accenture-Tech-Vision-2025.pdf?utm_source=chatgpt.com
- Vision, T. 2025b. 'AI : A Declaration of Autonomy'.
- Vogt, C. 2022. 'Deep Seabed Mining : Environmental Assessment and Management Guidelines Step by Step Process to Evaluate Applications for Deep Seabed Mining', (May).

A systematic review of hybrid quadrotor-track subsea robotic crawler for offshore mineral mining

- Wang, C., Cheng, C., Yang, D., Pan, G., Zhang, F. 2022. 'Path Planning in Localization Uncertain Environment Based on Dijkstra Method'. *Frontiers in Neurorobotics*, vol. 16 (March), pp. 1–12. Available at: <https://doi.org/10.3389/fnbot.2022.821991>
- Wang, J., Guo, J. 2023. 'Risk pre-control mechanism of mines based on evidence-based safety management and safety big data'. *Environmental Science and Pollution Research*, vol. 30, no. 51, pp. 111165–111181. Available at: <https://doi.org/10.1007/s11356-023-30204-5>
- Wang, L., Kang, Y., Wang, Y., Zhao, Z., Shang, L., Song, X., Xu, D., Cheng, R. 2024. 'Optimization Design of a Winch Suction Underwater Dredging Robot Using Orthogonal Experimental Design'. *Journal of Marine Science and Engineering*, vol. 12, no. 5. Available at: <https://doi.org/10.3390/jmse12050741>
- Wang, S., Ahmad, N.S. 2024. 'A Comprehensive Review on Sensor Fusion Techniques for Localization of a Dynamic Target in GPS-Denied Environments'. *IEEE Access*, p. 1. Available at: <https://doi.org/10.1109/ACCESS.2024.3519874>
- Wang, X., Tu, R., Zhang, R., Han, J., Fan, L., Zhang, P. 2020. 'A study of GPS PPP velocity estimation with the constraints of Doppler observation'. *Advances in Space Research*, vol. 66, no. 12, pp. 2900–2913. Available at: <https://doi.org/10.1016/j.asr.2020.05.011>
- Wang, Y., Cai, B., Zhang, Y., Liu, J., Khan, J., Liu, Y., Li, R., Chu, Z., Liu, Z., Liu, Y. 2022. 'Condition-based maintenance method for multicomponent system considering maintenance delay based on remaining useful life prediction: Subsea tree system as a case'. *Ocean Engineering*, vol. 266. Available at: <https://doi.org/10.1016/j.oceaneng.2022.112616>
- Wang, Z., Lei, Y., Wu, Z., Wu, J., Zhang, M., Liao, R. 2023. 'Structure Size Optimization and Internal Flow Field Analysis of a New Jet Pump Based on the Taguchi Method and Numerical Simulation'. *Processes*, vol. 11, no. 2. Available at: <https://doi.org/10.3390/pr11020341>
- Wang, Z., Rao, Q., Liu, S. 2011. 'Dynamic analysis of seabed-mining machine-flexible hose coupling in deep sea mining'. *Proceedings of the ISOPE Ocean Mining Symposium*, pp. 143–148.
- WEGA. 2013. 'Environmental issues associated with cremation', pp. 1–10. Available at: www.epa.gov
- Wei, T., Feng, W., Chen, Y., Wang, C.-X., Ge, N., Lu, J. 2021. 'Hybrid Satellite-Terrestrial Communication Networks for the Maritime Internet of Things: Key Technologies, Opportunities, and Challenges', pp. 1–27. Available at: <https://arxiv.org/pdf/1903.11814>
- Weiser, L. Officer, communications 2018. 'Deep-sea Mining: The Basics Overview', June. Available at: https://www.pewtrusts.org/-/media/assets/2018/07/deep-seabed-mining-basics_18-06-v3.pdf
- West-Trak 2019. 'Undercarriage Helping You get the Most from Your Undercarriage Tips for new undercarriage installations', <http://www.west-trak.co.nz/> [Preprint]. Available at: <https://www.west-trak.co.nz/wp-content/uploads/2019/01/Undercarriage-Handbook-low-res.pdf>
- Whittle, D., Yellishetty, M. 2023. 'Critical minerals', *Critical Materials and Sustainability Transition*, pp. 102–130. Available at: <https://doi.org/10.1201/9781003218920-7>
- World Energy Perspective - Energy Efficiency Technologies (2013) 'World Energy Perspective - Energy Efficiency Technologies'. World Energy Council, pp. 5–26. Available at: <http://www.worldenergy.org/wp-content/uploads/2014/03/World-Energy-Perspectives-Energy-Efficiency-Technologies-Overview-report.pdf>
- Wu, H., Zeng, X., Xiao, J., Yu, Y., Dai, X., Yu, J. 2020. 'Vector form intrinsic finite-element analysis of static and dynamic behavior of deep-sea flexible pipe'. *International Journal of Naval Architecture and Ocean Engineering*, vol. 12, pp. 376–386. Available at: <https://doi.org/10.1016/j.ijnaoe.2020.04.003>
- Xia, M., Lu, H., Yang, J., Sun, P. 2023. 'Multi-Body Dynamics Modeling and Straight-Line Travel Simulation of a Four-Tracked Deep-Sea Mining Vehicle on Flat Ground'. *Journal of Marine Science and Engineering*, vol. 11, no. 5, p. 36. Available at: <https://doi.org/10.3390/jmse11051005>
- Xiao, Z., Li, C., Dai, B., Zhao, D., Xiao, L., Nie, Y., Hu, Y., Li, X. 2024. 'Autonomous Driving in Unstructured Environments: How Far Have We Come?', vol. 2, pp. 1–38. Available at: <http://arxiv.org/abs/2410.07701>
- Xiao, J., Hong, S., Yang, N., Xiong, H., Liu, J., Ou, W., Parianos, J., Chen, Y. 2019. 'Model test of skip lifting system for deep-sea mining'. *Proceedings of the International Offshore and Polar Engineering Conference*, 1 November, pp. 134–139.
- Xiao, L.-j., Liu, Q., Lu, J.-m. 2020. 'Analysis on longitudinal vibration law of deep sea stepped mining pipe'. *AIP Advances*, vol. 10, 12, pp. 1–15. Available at: <https://doi.org/10.1063/5.0032731>
- Xiao, X., Liu, B., Warnell, G., Stone, P. 2022. Motion planning and control for mobile robot navigation using machine learning: a survey. *Autonomous Robots*. Available at: <https://doi.org/10.1007/s10514-022-10039-8>
- Xie, C., Wang, L., Yang, N., Agee, C., Chen, M., Zheng, J., Liu, J., Chen, Y., Xu, L., Qu, Z., Yao, S., Wang, L., Chen, Z. 2022. 'A Compact Design of Underwater Mining Vehicle for the Cobalt-Rich Crust with General Support Vessel Part A: Prototype and Tests'. *Journal of Marine Science and Engineering*, vol. 10, no. 2. Available at: <https://doi.org/10.3390/jmse10020135>
- Xie, Y., Liu, C., Chen, X., Liu, G., Leng, D., Pan, W., Shao, S. 2023. 'Research on path planning of autonomous manganese nodule mining vehicle based on lifting mining system'. *Frontiers in Robotics and AI*, 10 July, pp. 1–12. Available at: <https://doi.org/10.3389/frobt.2023.1224115>
- Xu, J., Irigoien, X., Alouini, M.-S. 2024. 'State-of-the-Art Underwater Vehicles and Technologies Enabling Smart Ocean: Survey and Classifications', pp. 1–35. Available at: <http://arxiv.org/abs/2412.18667>
- Xu, W., Saint, R., Gruyer, D., Orfila, O. 2021. 'Safe vehicle trajectory planning in an autonomous decision support framework for emergency situations'. *Applied Sciences*, vol. 11, no. 14. Available at: <https://doi.org/10.3390/app11146373>
- Yang, H., Boyang, L., Jiang, B., Han, J., Wen, C.Y. 2024. 'Disturbance Observer-Based Model Predictive Control for an Unmanned Underwater Vehicle'. *Journal of Marine Science and Engineering*, vol. 12, no. 1. Available at: <https://doi.org/10.3390/jmse12010094>
- Yang, Y., Mao, Y., Sun, B. 2020. 'Basic performance and future developments of BeiDou global navigation satellite system'. *Satellite Navigation*, vol. 1, no. 1, pp. 1–8. Available at: <https://doi.org/10.1186/s43020-019-0006-0>

A systematic review of hybrid quadrotor-track subsea robotic crawler for offshore mineral mining

- Yang, Z., Lu, Q., Yan, J., Chen, J., Yue, Q. 2018. 'Multidisciplinary optimization design for the section layout of umbilicals based on intelligent algorithm'. *Journal of Offshore Mechanics and Arctic Engineering*, vol. 140, no. 3. Available at: <https://doi.org/10.1115/1.4038580>
- Yaqot, M., Menezes, B.C. 2023. 'Mining Process Systems in the Industry 4.0 Mandate Towards the Plant of Future', (April), pp. 713–721. Available at: <https://doi.org/10.46254/eu05.20220145>
- Yaroshenko, I., Kirsanov, D., Marjanovic, M., Lieberzeit, P., Korostynska, O., Mason, A., Frau, I., Legin, A. 2020. 'Real-time water quality monitoring with chemical sensors'. *Sensor*, vol. 20, no. 12, pp. 1–22. Available at: <https://doi.org/10.3390/s20123432>
- Yeu, T., Yoon, S., Park, S., Hong, S., Choi, J., Kim, H., Kim, D., Lee, C. 2011. 'Estimation of MineRo's kinematic parameters for underwater navigation algorithm'. *Ocean and Polar Research*, vol. 33, no. 1, pp. 69–76. Available at: https://www.researchgate.net/publication/339680113_Optimal_path_planning_based_on_A_algorithm_for_submarine_mining_vehicle
- Yoo, T.S., Kang, S.H., Lee, J., Ji, D., Kim, M.H. 2025. 'Development and Evaluation of Enhanced Navigation Filters for Underwater Glider'. *IEEE Access*, p. 1. Available at: <https://doi.org/10.1109/ACCESS.2025.3539247>
- Yoon, S.M., Hong, S., Park, S.J., Choi, J.-S., Kim, H.-W., Yeu, T.-K. 2012. 'Track velocity control of crawler type underwater mining robot through shallow-water test'. *Journal of Mechanical Science and Technology*, vol. 26, no. 10, pp. 3291–3298. Available at: <https://doi.org/10.1007/s12206-012-0810-2>
- Yu, D., He, Z. 2022. Digital twin-driven intelligence disaster prevention and mitigation for infrastructure: advances, challenges, and opportunities. *Natural Hazards*. Springer Netherlands. Available at: <https://doi.org/10.1007/s11069-021-05190-x>
- Yum, K.K., Skjong, S., Taskar, B., Pedersen, E., Steen, S. 2016. Simulation of a Hybrid Marine Propulsion System in Waves. *Proceedings of 28th CIMAC World Congress*. Available at: https://www.researchgate.net/publication/303793681_Simulation_of_a_Hybrid_Marine_Propulsion_System_in_Waves
- Yurish, S.Y. 2020. *Advances in Robotics and Automatic Control: Reviews*, Advances in Robotics and Automatic Control: Reviews Book Series, vol. 1
- Zeng, X., Xia, M., Luo, Z., Shang, J., Xu, Y., Yin, Q. 2022. 'Design and Control of an Underwater Robot Based on Hybrid Propulsion of Quadrotor and Bionic Undulating Fin'. *Journal of Marine Science and Engineering*, vol. 10, 9. Available at: <https://doi.org/10.3390/jmse10091327>
- Zhang, L., Li, Y., Meng, Y., Wang, L., Jia, P. 2018. 'Installation and Docking Technology of Control Module for Subsea Production System', (March). Available at: <https://doi.org/10.2991/mecae-18.2018.69>
- Zhang, X., Zuo, Y., Wei, J., Sha, F., Yuan, Z., Liu, X., Xi, M., Xu, J. 2024. 'A Review on Underwater Collection and Transportation Equipment of Polymetallic Nodules in Deep-Sea Mining'. *Journal of Marine Science and Engineering*, vol. 12, no. 5. Available at: <https://doi.org/10.3390/jmse12050788>
- Zhao, R., Zou, G., Su, Q., Zou, S., Deng, W., Yu, A., Zhang, H. 2022. 'Digital Twins-Based Production Line Design and Simulation Optimization of Large-Scale Mobile Phone Assembly Workshop'. *Machines*, vol. 10, no. 5. Available at: <https://doi.org/10.3390/machines10050367>
- Zheng, D., Wang, H., Xie, Z., Chen, W., Kong, X. 2017. 'Autonomous navigation of a quadrotor in unknown environments'. 2017 *IEEE International Conference on Robotics and Biomimetics, ROBIO 2017*, 2018-Janua(November 2022), pp. 1930–1935. Available at: <https://doi.org/10.1109/ROBIO.2017.8324701>
- Zhong, D., Xie, Z., Zhu, Y., Duan, J. 2023. 'Overview of predictive maintenance based on digital twin technology'. *Heliyon*, vol. 9, no. 4, p. e14534. Available at: <https://www.sciencedirect.com/science/article/pii/S2405844023017413>
- Zhong, J., Li, M., Chen, Y., Wei, Z., Yang, F., Shen, H. 2024. 'A Safer Vision-Based Autonomous Planning System for Quadrotor UAVs with Dynamic Obstacle Trajectory Prediction and Its Application with LLMs'. *Proceedings - 2024 IEEE Winter Conference on Applications of Computer Vision Workshops, WACVW 2024*, pp. 920–929. Available at: <https://doi.org/10.1109/WACVW60836.2024.00131>
- Zhu, J., Li, H., Zhang, T. 2024. 'Camera, LiDAR, and IMU Based Multi-Sensor Fusion SLAM: A Survey'. *Tsinghua Science and Technology*, vol. 29, no. 2, pp. 415–429. Available at: <https://doi.org/10.26599/TST.2023.9010010>
- Zhu, Q., Yu, B., Wang, Z., Tang, J., Chen, Q., Li, Z., Liu, X., Luo, Y., Tu, L. 2023. Cloud and Edge Computing for Connected and Automated Vehicles. Available at: <https://www.emerald.com/fteda/article-abstract/14/1-2/1/1320869/Cloud-and-Edge-Computing-for-Connected-and?redirectedFrom=fulltext>
- Zhu, W., Shi, X., Huang, R., Huang, L., Ma, W. (2021). 'Research on coupled thermo-hydro-mechanical dynamic response characteristics of saturated porous deep-sea sediments under vibration of mining vehicle'. *Applied Mathematics and Mechanics* (English Edition), vol. 42, no. 9, pp. 1349–1362. Available at: <https://doi.org/10.1007/s10483-021-2768-5>
- Zhukabayeva, T., Zholshiyeva, L., Karabayev, N., Khan, S., Alnazzawi, N. 2025. 'Cybersecurity Solutions for Industrial Internet of Things–Edge Computing Integration: Challenges, Threats, and Future Directions'. *Sensors*, vol. 25, no. 1. Available at: <https://doi.org/10.3390/s25010213>
- Zimmermann, M., Wotawa, F. 2020. 'An adaptive system for autonomous driving'. *Software Quality Journal*, vol. 28, no. 3, pp. 1189–1212. Available at: ◆